



十速科技股份有限公司
tenx technology inc.

**Advance
Information**

TICE87NB Hardware User Manual

**Tenx reserves the right to change or
discontinue this product without notice.**

Preliminary

tenx technology, inc.

Rev 1.2, 2008/06/24

CONTENTS

1. Hardware Accessories 2

2. MCU Models that it can support 2

3. Installation 3

4. Manual for Panel Use..... 4

1. Hardware Accessories

- ICE 1 set
- TM8795 Writer Board 1 set
- DC Adapter 1 pcs
- Printer port cable 1 pcs
- Bus line (16pin) 1 pcs
- Bus lines (40pin) 2 pcs
- Installation CD 1 pcs
- One copy of hardware installation

2. MCU Models that it can support

This development can support the following 4-bit MCU products:

TM8704, TM8705, TM8706, TM8712, TM8713, TM8720, TM8721, TM8722, TM8723, TM8724, TM8725, TM8726, TM8727, TM8740^(Note-1), TM8795, TM87P08, TM87P04^(Note-2).

Note-1: If clients need to develop TM8740 products, the products have to be used together with TX9010 EV Board. Please contact with our sales department and gain the detail information.

Note-2: TM8795, TM87P08, TM87P04 are the OPT products.

3. Installation

Step-1: Please make sure the printer port on the computer is set to be EPP Mode.

Step-2: Connect printer port cable to the computer and the printer port on ICE, as shown in Figure-1.



Figure-1

Step-3: Insert the DC Adapter to ICE, as shown in Figure-2.



Figure-2

Step-4: Turn Power switch to ON position.

Hardware is installed on your computer successfully.

Now, you can start to install software. First, put the CD disk into the computer. Then, follow the instruction to install software Application. After the completion, the operation may begin.

4. Manual for Panel Use

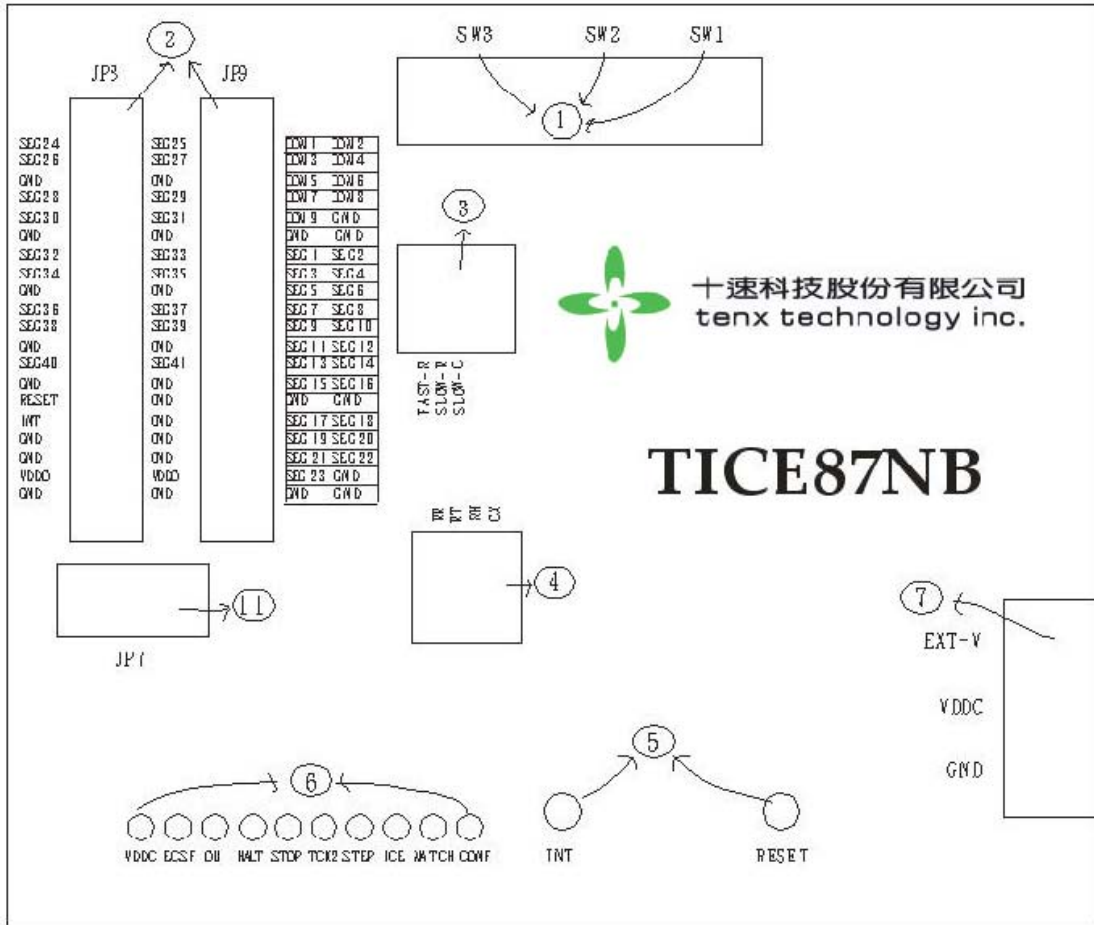

Figure-3

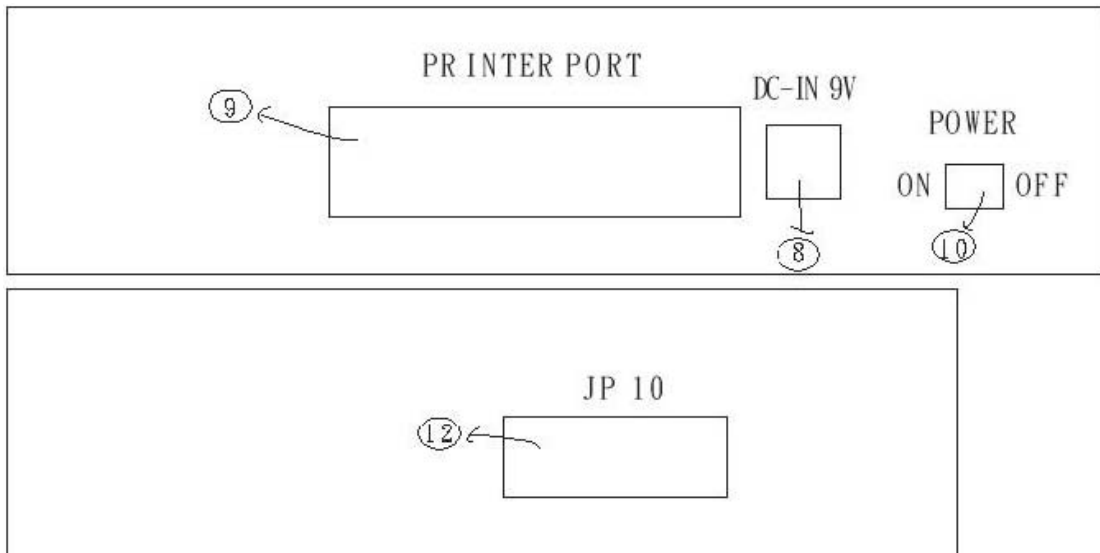

Figure-4

4-1. SW1, SW2, SW3

- SW1: Set the work voltage of chip and please refer the details to Table-1.
- SW2: Set LCD BIAS and please refer the details to Table-2.
- SW3: Set LCD Pump voltage and please refer the details to Table-3.

Table-1: POWER SETTING

SW1 of VDDO settint					
Function	Bit1	Bit2	Bit3	Bit4	Bit5
5v	1	0	0	0	0
3v	0	1	0	1	0
1.5v	0	0	1	1	0
EXT-V	0	0	0	0	1

Table-2: CUP0~CUP2 CAP SETTING

SW2 CAP of CUP0~CUP2 setting				
Function	Bit1	Bit2	Bit3	Bit4
DC	0	0	0	0
1/2 BIAS	0	0	1	1
1/3 BIAS	0	0	1	1
1/4 BIAS	1	1	1	1

Table-3: VDD1~VDD4 CAP SETTING

SW3 CAP of VDD1~VDD4 setting								
Function	Bit1	Bit2	Bit3	Bit4	Bit5	Bit6	Bit7	Bit8
DC	1	0	1	0	1	0	1	0
1.5V Ag 1/2	1	0	0	1	1	0	1	0
1.5V Ag 1/3	1	0	0	1	0	1	1	0
1.5V Ag 1/4	1	0	0	1	0	1	0	1
3V Li 1/2	0	1	1	0	1	0	1	0
3V Li 1/3	0	1	1	0	0	1	1	0
3V Li 1/4	0	1	1	0	0	1	0	1

Note: 1: ON. 0: OFF.

Example: When you set the operation voltage values of *.opt as 3V and 1/4BIAS, please adjust the SW1, SW2 and SW3 as Figure-5.

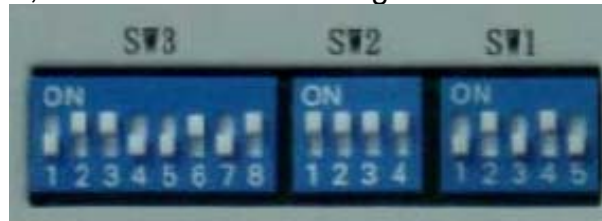

Figure-5

4-2. JP8, JP9: Connect to external testing boards or LCD panel signal. Please refer to Figure-6.

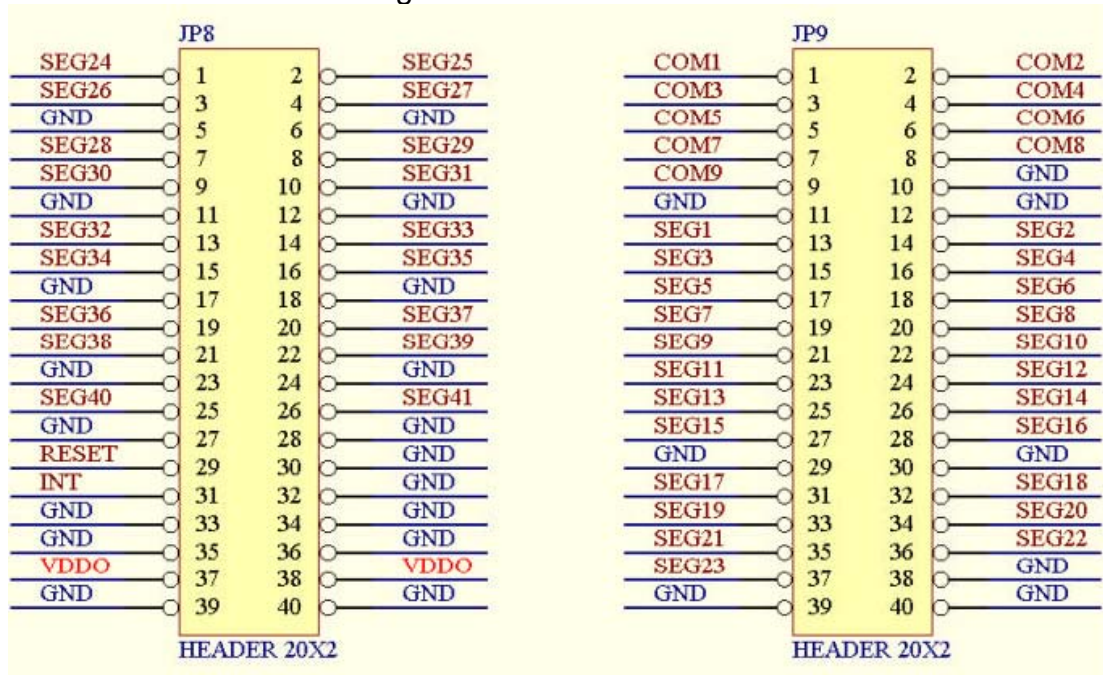

Figure-6

4-3. External pins for External clock: Fast-R and Slow-R&C. (Note-1)
 Example-1: Refer to Figure-7 for the way of connecting Fast-R pin.

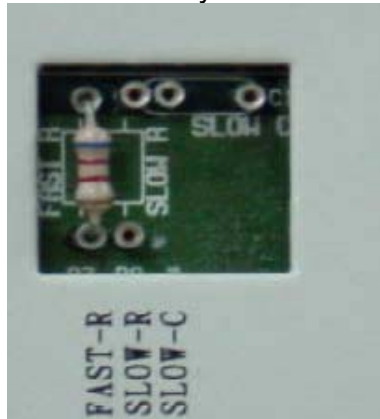

Figure-7

Example-2: Refer to Figure-8 for the way of connecting Slow-R&C pin.

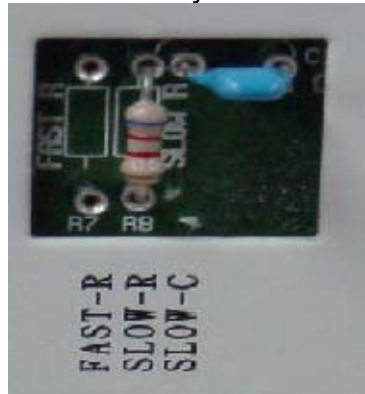

Figure-8

Note-1: In Debug mode (step, go), all clocks are provided from ICE internal. Therefore, the external clock will only work during the execution of Free run mode.

4-4. RFC external pins: RR, RT, RH and CX.

Example-1: Refer to Figure-9 for the way of connecting RR, RT, RH and CX pin.



Figure-9

4-5. Reset, INT buttons:

- Reset: Chip reset request signal.
- INT: External interrupt request signal.
- Please refer to each Chip user's manual for detail information.

4-6. LED Status Display: (Hi => ON; Lo => OFF)

- VDDC: ICE POWER. (ON: Hi; OFF: Lo)
- ECSF: Fast / Slow clock status. (Fast: Hi; Slow: Lo)
- OU: STACK Over/Underflow status. (STACK Over/Underflow: Hi; normal: Lo)
- HALT: HALT status. (HALT mode: Hi; HALT release: Lo)
- STOP: STOP status. (STOP mode: Hi; HALT release: Lo)
- STEP: Free run/Single step status. (Free run: Lo; Single step: Hi)
- MATCH: Compare H/W (sw1, sw2, sw3) setup with S/W (.opt file) setup. (the same: Hi)

4-7. EXT-V, VDDC, GND:

- EXT-V: External Voltage
- VDDC: 5 voltage
- GND: ground

4-8. DC-IN: 9V DC input**4-9. Printer port: connect PC****4-10. Power switch****4-11. JP7: TM8740 Bus line for externally connected boards. Please refer to Figure-9.****Figure-9**

4-12. JP10: OTP Writer_Boare Bus line for externally connected boards. Please refer to Figure-10, Figure-11 and Figure-12. (Note-3)

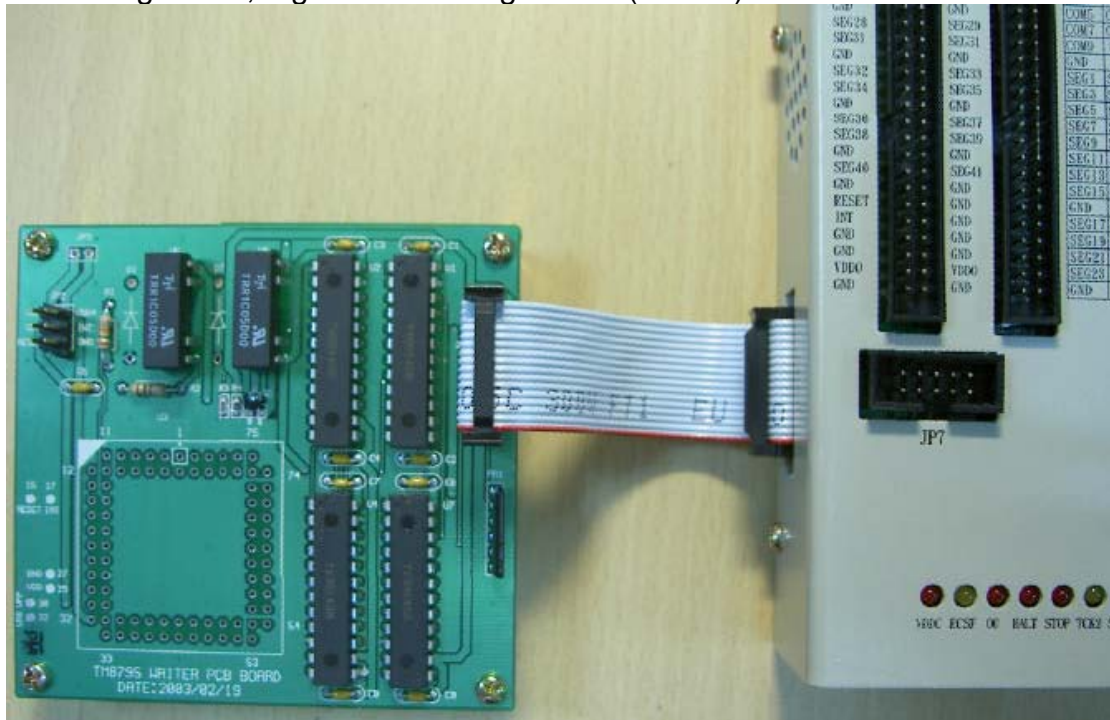

Figure-10

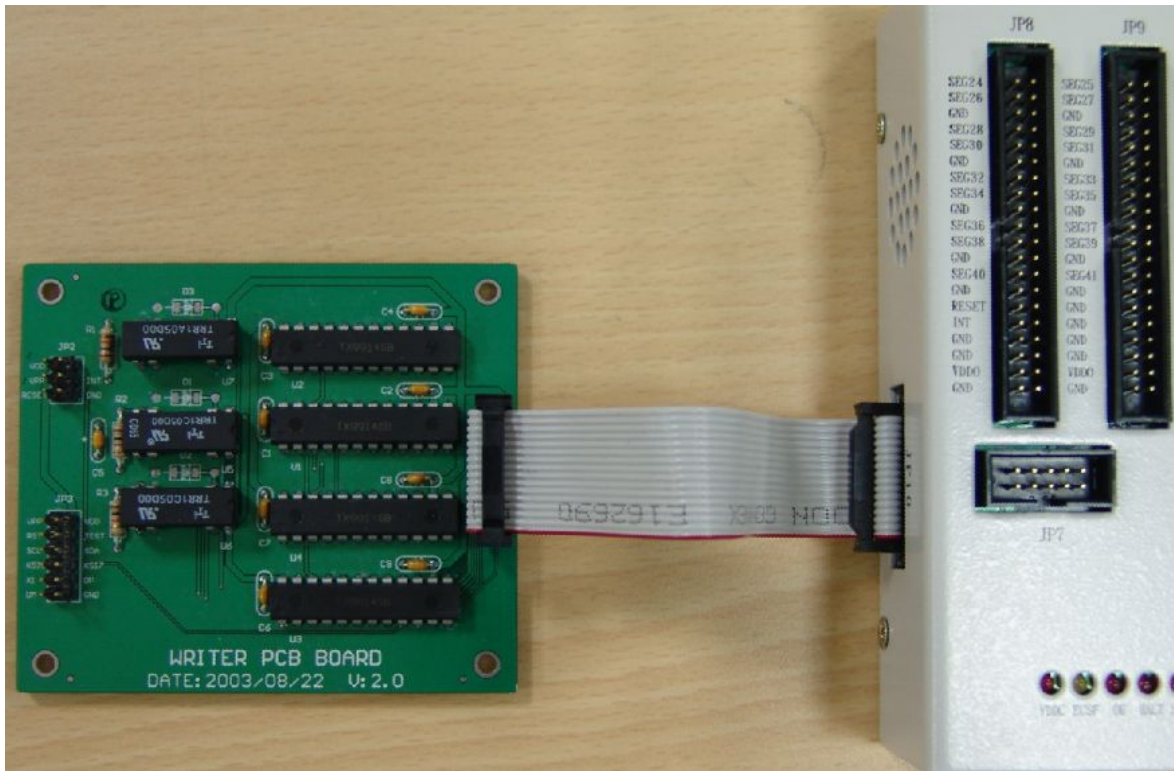

Figure-11

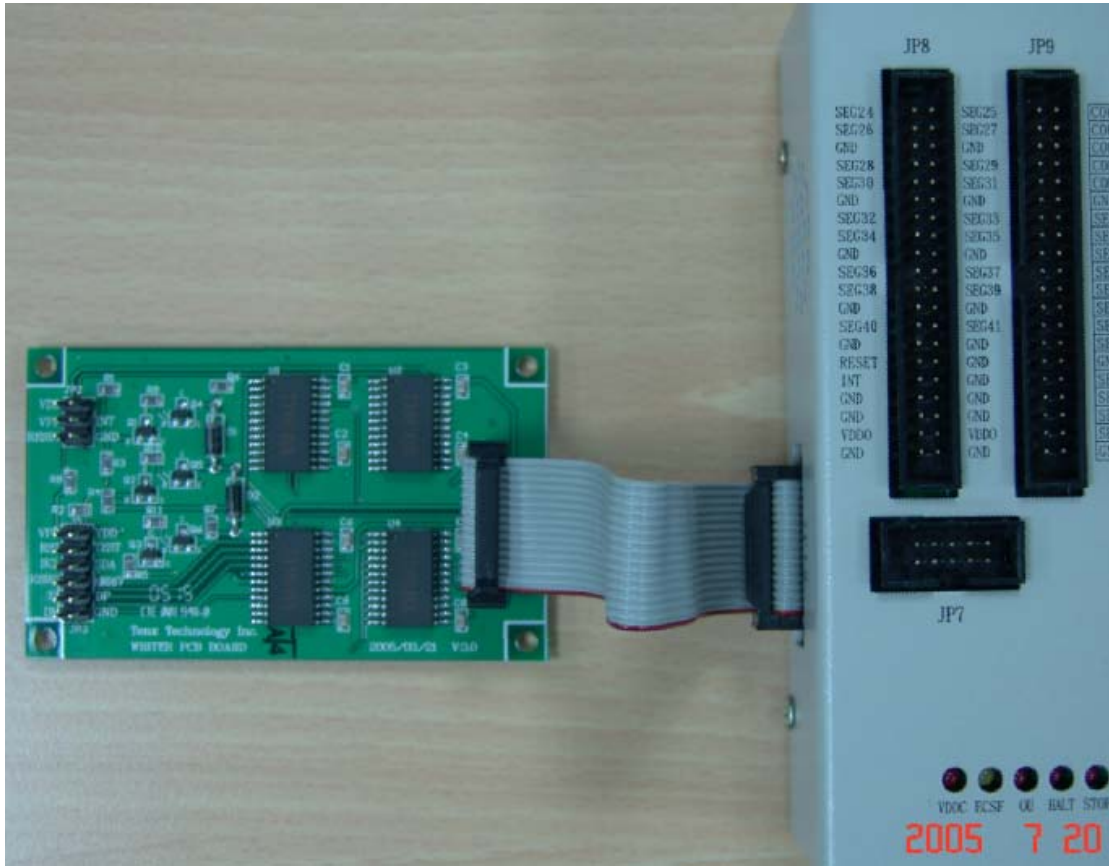

Figure-12

4-13. Writer_Boare: Please refer to Figure-13 and Figure-14. (Note-4)

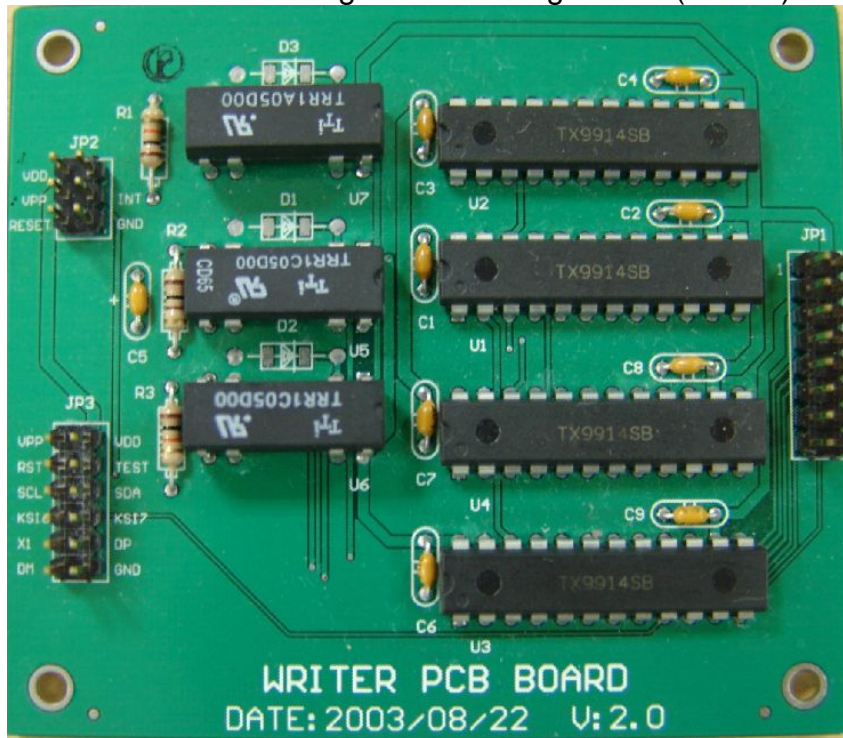

Figure-13

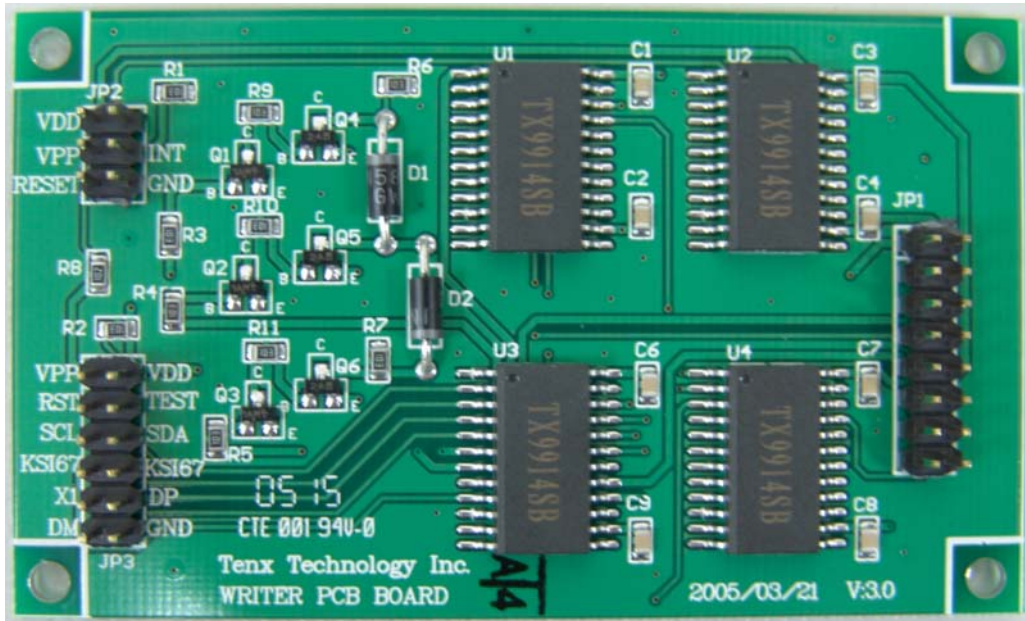

Figure-14

Note-3: WRITER BOARD user guide:

- The bus line (16pin) connects JP10 (TICE87NB) to JP1 (WRITER BOARD).
- The JP2 signal line connects to TM8795 and TM87P08 IC (OTP).

Note-4: OTP IC:

- a). The power source of TM8795/TM87P08 only support 3V/5V application.
- b). Program pin assignment: VDD (VDD2), VPP, INT, RESET, GND.
- c). In Normal mode, VPP must be connected to VDD2.