



十速科技股份有限公司
tenx technology inc.

**Advance
Information**

TMU3111

USB Full Speed Controller

Data Sheet

**Tenx reserves the right to change or
discontinue this product without notice.**

tenx technology inc.

tenx technology, inc.

Preliminary

Rev 1.1, 2009/07/23

CONTENTS

UM-TM58RC10_E..... 錯誤! 尚未定義書籤。

1. GENERAL DESCRIPTION 2

2. FEATURES..... 2

3. Functional Block Diagram 5

4. XRAM Data Path 6

5. Pin Description 7

6. CPU Operation Mode V.S. Peripheral Clock 8

7. Package 9

8. PAD List 11

9. Application Circuit 12

10. Electrical Characteristics 13

1. GENERAL DESCRIPTION

The TMU3111 is an 8051-based embedded device tailored to general USB full speed application. TMU3111 is designed for connecting PC or operating in stand-alone (non-PC) mode. It also supports the powerful functions and interfaces, such as 10-bit A/D converter for data acquisition and micro-phone recording, speech PWM output, master/slave SPI and external parallel bus (NOR, NAND interface).

2. FEATURES

(1). Dual Power System

- USB 5V and/or battery-in dual power systems

(2). Operation Frequency

- FAST mode
 - ◆ 6MHz crystal oscillator for PLL clock source, PLL generate 48MHz for USB data transaction and 24MHz/6MHz for CPU clock
- SLOW mode
 - ◆ External resistor, RC oscillator at 2.0V~3.6V for battery system (optional)
 - ◆ 32KHz crystal oscillator for CPU clock and accuracy timing in low power mode (optional)
- STOP mode

(3). On-Chip Memory

- 32k x 8 internal program OTP-ROM
- Internal RAM 256 bytes and external XRAM up to 320 bytes

(4). USB interface

- Compliance with Universal Serial Bus specification v2.0 Full Speed
- Built-in USB Transceiver, 3.3V regulator
- Software Control USB pull-up resistor
- Support USB Suspend /Resume and Remote Wakeup function
- Endpoint 0: Control SETUP transfer (8 bytes)
- Endpoint 0: Control IN/OUT transfer (64 bytes)
- Endpoint 1: BULK-IN transfer with Pin-Pong feature (2*64 bytes)
- Endpoint 2: BULK-OUT transfer with Pin-Pong feature (2*64 bytes)
- Endpoint 3: INTERRUPT IN transfer (8 bytes)

(5). ADC (Analog to Digital Converter)

- 20 analog input channels
- 10-bit SAR A/D converter

(6). Recording Function

- 8KHz sampling rate for voice recording
- Recorder AC Couple Out
- Recorder AC Couple In
- Built-in Microphone Booster (Pre_Amp)

(7). Speech PWM Out

- 8-bit unsigned PCM format
- 8KHz sampling rate for Audio Playback
- Class-D Amplify for Speaker Out

(8). NOR Interface

- Data transfer for all of External XRAMs
- H/W handle NOR command procedure
- Read DMA (up to 64 bytes per time)
- Write DMA (up to 64 bytes per time)

(9). NAND Interface

- Data transfer for all of External XRAMs
- Write DMA (up to 64 bytes per time)
- Read DMA (up to 64 bytes per time)
- Compatible with 8-bit parallel interface

(10). SPI Interface

- Mode0, 1, 2, 3
- Master or Slave mode
- Clock Rate up to 12Mbps
- Read DMA (up to 64 bytes per time)
- Write DMA (up to 64 bytes per time)

(11). PWM

- Support 2 channels of Pulse Width Modulation (PWM) function with 8-bit resolution

(12). Reset Controller

- Power On Reset
- Low Voltage Reset
- Watch-Dog Timer
- USB Plug-in Reset
- Plug-out Reset

(13). Keep SRAM data when USB un-plug (need battery)**(14). I/O Ports**

- Max. 50 GPIOs to flexible application
- 4 external Interrupts with wakeup function

(15). LQFP80 / Die Form / Customer Request**(16). Application**

- USB full speed general purpose
- Portable picture viewer equipment (Digital Portable Framer)
- Voice Interactive Toy
- Voice Recording Toy
- Downloadable voice / storage application via Internet

3. Functional Block Diagram

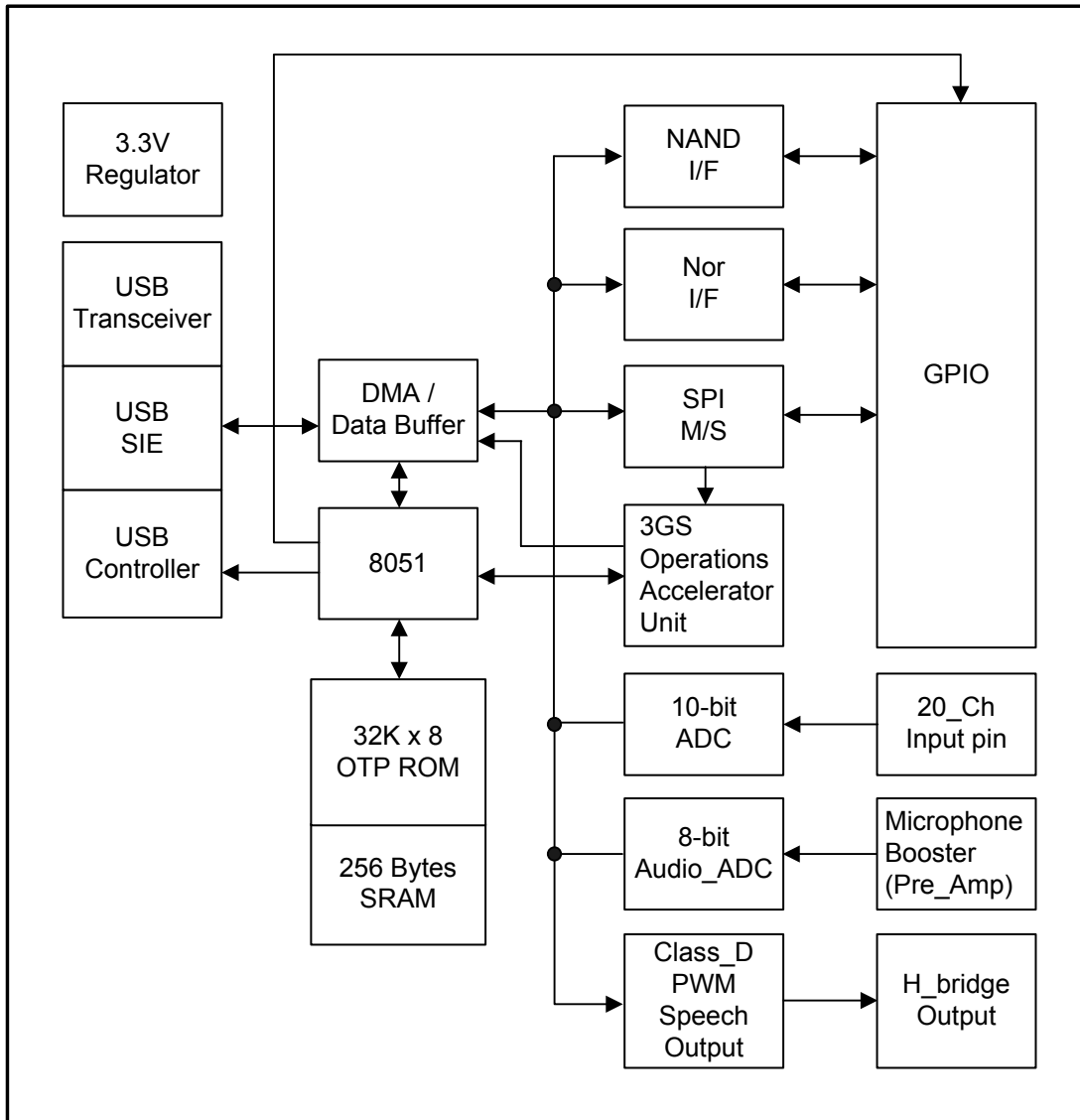

4. XRAM Data Path

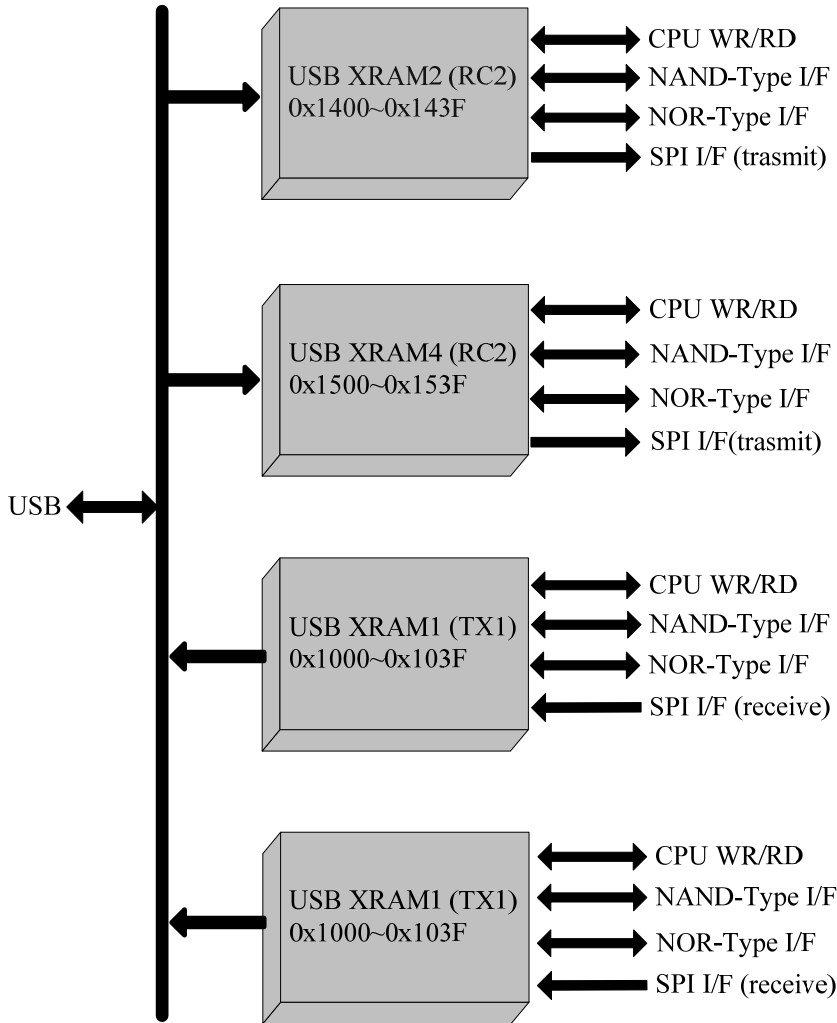

5. Pin Description

Name	I/O	Description				
DVDD	P	5V Power from USB cable				
DGND	P	Ground				
PC5VDET	I	USB 5V detection pin, should connect to USB power				
VBAT	P	Battery power in				
V33	O	3.3V regulator output				
DP	I/O	USB positive data signal				
DM	I/O	USB negative data signal				
VPP/RESEn	I	OTP programming power/Chip reset pin (internal pull-up)				
TESTn[1:0]	I	Test Mode control (internal pull-up)				
FX1	I	Crystal in (6MHz)				
FX2	O	Crystal out				
VDDX	P	PLL power				
FLTC	I	PLL filter				
VSSX	P	PLL ground				
LX1	I	Crystal in (32KHz)				
LX2	O	Crystal out				
VR	I	RCLK clock, external resistor				
P1[7:0]	I/O	8051's Port1				
P3[1:0]	I/O	8051's Port3[1:0]				
P3.5/T0	I/O	8051's Port3.5 / Timer 0				
P3.4/T1	I/O	8051's Port3.4 / Timer 1				
PA[7:0]		GPIO (b)	ADC_CH[07:00] (i)	NOR_FA[7:0] (o)		
PB[3:0]		GPIO (b)		NOR_FD[3:0] (b)	NAND_DIO[3:0] (b)	
PB[7:4]		GPIO (b)	ADC_CH[19:16] (i)	NOR_FD[7:4] (b)	NAND_DIO[7:4] (b)	
PC[0]		GPIO with wake-up interrupt (b)		NOR_WRN (o)	NAND_WRN (o)	
PC[1]		GPIO with wake-up interrupt (b)		NOR_RDN (o)	NAND_RDN (o)	
PC[2]		GPIO with wake-up interrupt (b)				
PC[3]		GPIO with wake-up interrupt (b)				
PC[4]		GPIO (b)				PWMB out (o)
PC[5]		GPIO (b)				PWMA out (o)
PC[6]		GPIO (b)				SPICLK M(o), S(i)
PC[7]		GPIO (b)				SPI DOUT (o)
PE[7:0]		GPIO (b)	ADC_CH[15:8] (i)			ICE pins
PF[3:0]		GPIO (b)		NOR_FA[11:8] (o)		
PF[4]		GPIO				SPI DIN (i)
PF[5]		GPIO				SPI CSN (i)
ADC:						
AVDD	P	Analog Power				
AGND	P	Analog Ground				
MICP	I	Micro-phone MIC IN+ input				
MICN	I	Micro-phone MIC IN- input				
VREF	I	External reference voltage				
ANAI	I	AC couple in				
ANAO	O	AC couple out				
Speech PWM:						
VDDW	P	PWM Power				
PWMP	O	Speech PWMP output				
PWMN	O	Speech PWMN output				
VSSW	P	PWM Ground				

All I/O ports are pseudo-open drain types, unless otherwise specified function.

6. CPU Operation Mode V.S. Peripheral Clock

	DUAL MODE ⁽¹⁾		SIGNLE MODE ⁽¹⁾	NOTE
	SLOW ⁽²⁾	FAST ⁽²⁾		
CPUCLK(CPU51)	RCLK/32KHz	6M/24MHz	6M/24MHz	
USB function	N/A	48MHz	48MHz	
NAND DMA	N/A	6MHz	6MHz	XTAL_EN = 1
NOR DMA	N/A	6MHz	6MHz	
A/D converter	N/A	6MHz	6MHz	
Recording	N/A	6MHz	6MHz	
Speech PWM	N/A	6MHz	6MHz	
SPI	CPUCLK	CPUCLK	CPUCLK	
WDT	CPUCLK	CPUCLK	CPUCLK	
PWMA/B	CPUCLK	CPUCLK	CPUCLK	
0.5sec timer wakeup Interrupt	0.5sec	0.5sec	0.5sec	If 32KHz Xtal ⁽³⁾ is available

Notes:

(1) & (3) Function enable/disable control by FUSE option.

(2) CPU clock mode switching control by firmware.

7. Package

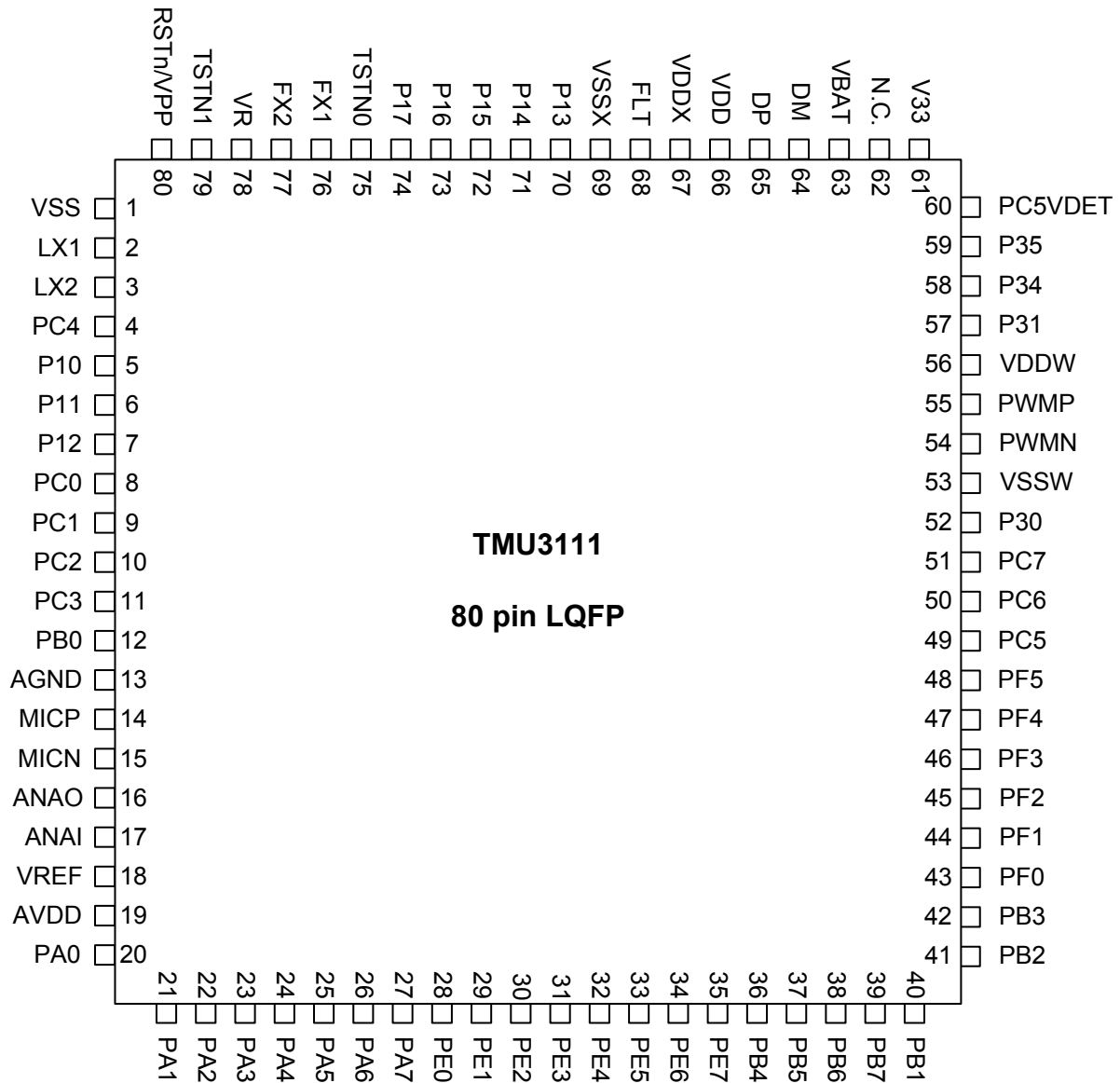

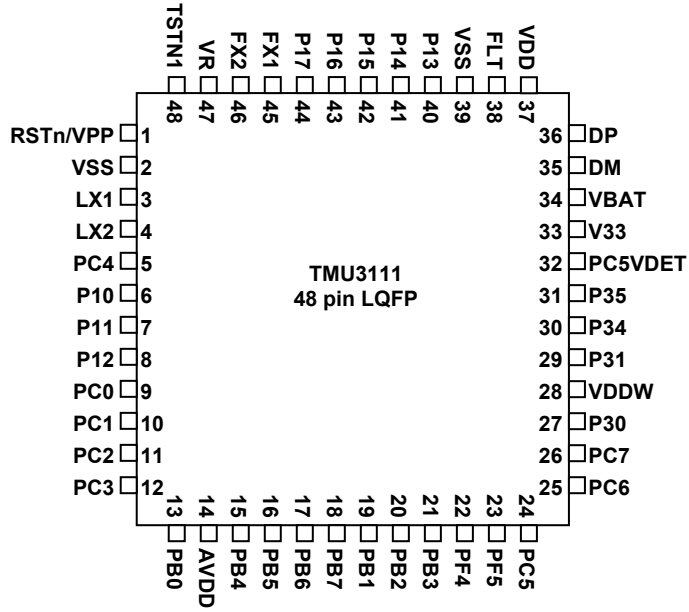

9. Application Circuit

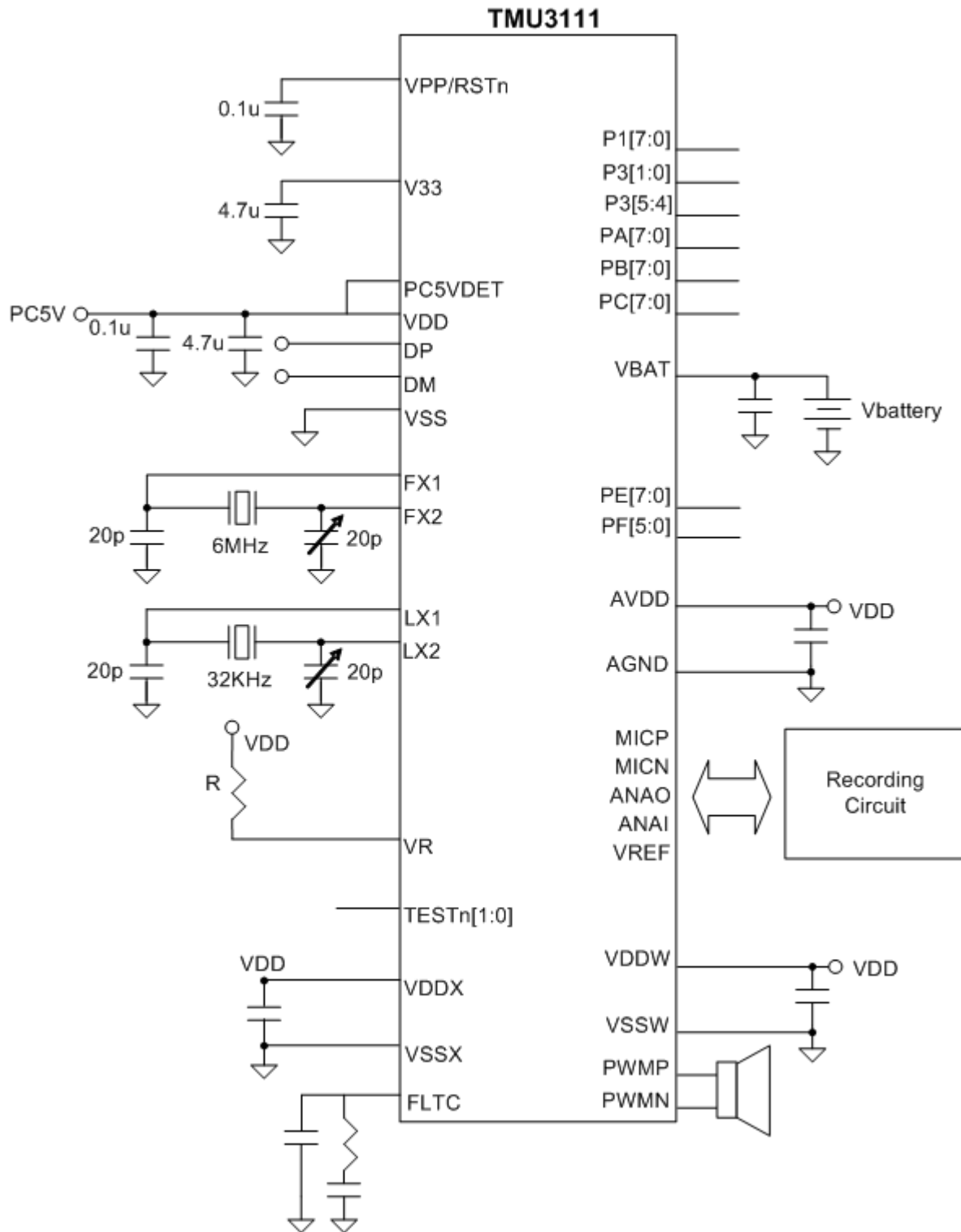

10. Electrical Characteristics

(1). ABSOLOUTE MAXIMUM RATINGS (GND = 0V)

Name	Symbol	Range	Unit
Maximum Supply Voltage	VDD	-0.3 to 5.5	V
Maximum Input Voltage	Vin	-0.3 to VDD + 0.3	V
Maximum output Voltage	Vout	-0.3 to VDD + 0.3	V
Maximum Operating Temperature	Topg	-10 to + 70	°C
Maximum Storage Temperature	Tstg	-25 to + 125	°C

(2). RECOMMEND OPERATING CONDITION (at Ta = -10°C to 70°C, GND = 0V)

Name	Symb.	Min.	Max.	Unit
Supply Voltage	VDD	2.2	5.5	V
Battery Voltage, if apply	Vbat	2.2	4.2	V
Input "H" Voltage	Vih	0.9 x VDD	VDD	V
Input "L" Voltage	Vil	0	0.1 x VDD	V

(3). DC CHARACTERISTICS

(at Ta = 25°C, VDD = 5.0V, VSS = 0V, unless otherwise specify)

Name	Symb.	Min.	Typ.	Max.	Unit	Condition	Note
FAST clock	fclk1		24		MHz	XT6MHz On, PLL enable	
	fclk2		6		MHz	XT6MHz On	
SLOW clock	sclk1	0.1		10	MHz	VBAT = 3.0V, VDD = N.C.	
	sclk2		32		KHz	XT32KHz On	
Operating current	lcc1		10		mA	fclk1 = 24MHz, XT6MHz On	No load
	lcc2		0.8		mA	XT6MHz Off, RCLK = 3MHz VBAT = 3.0V, VDD = N.C.	No load
Suspend current	lsus		360	500	uA	USB mode	No load
Power down current	lpd1		3	5	uA	VDD = 3.0v, XT32KHz Off	No load
Output high current	loh1	2.5	3.8	-	mA	Voh = 3.0v, Vbat = 3.3v, VDD = N.C.	One clk time
	loh2	4	6	-	uA		
	loh3	2.5	3.8	-	mA		PWMA/B
	loh4	60	70	-	mA	VDD = 3.3V, Voh = VDD/2	Sph. PWM
Output low current	lol1	10	15	-	mA	Vol = VSS + 0.4v,	GPIO
	lol2	20	25	-	mA	Vol = VSS + 0.4v	PWMA/B
Input high voltage	Vih1	1.6		VDD	V	VDD = 3.2V, Vio = V33 = 3.2V PC5V = 0, Schmitt trigger	GPIO
	Vih2	1.7		VDD	V	VDD = 5.0V, Vio = V33 = 3.3V, PC5V > Vih3, Schmitt trigger	GPIO
	Vih3	2.8		VDD	V	Schmitt trigger	PC5V
Input low voltage	Vil1			1.3	V	VDD = 3.2V, Vio = V33 = 3.2V PC5V = 0, Schmitt trigger	GPIO
	Vil2			1.4	V	VDD = 5.0V, Vio = V33 = 3.3V PC5V > Vih3, Schmitt trigger	GPIO
	Vil3			1.4	V	Schmitt trigger	PC5V

Pull up resistance	Rup1	5	10	15	K Ω	VDD = 3.3 or 5V	VPP/RSTn
	Rup2	40	50	60	K Ω	VDD = 5V	TEST pin
Pull down resistance	Rdn1	50	100	150	K Ω	PC5V	
V33 pin voltage	V33	3.0	3.3	3.6	V	130mA, PC5V > Vih3	

(4). A/D conversion

(at Ta = 25°C, VDD = AVDD = 5.0V, VSS = AGND = 0V, unless otherwise specify)

Name	Symb.	Min.	Typ.	Max.	Unit	Condition	Note
Resolution		-	10	-	Bits		
Conversion time	Tadc		24		us	Fadc=1.5MHz	
Differential linearity	DL		± 2.5	± 4	LSB		
Linearity	IL		± 3.2	± 5	LSB		
Total error	ERR		± 4	± 6	LSB		

(5). USB AC CHARACTERISTICS

(at Ta = 25°C, VDD = AVDD = 5.0V, VSS = AGND = 0V)

Name	Symb.	Min.	Typ.	Max.	Unit	Note
DP/DM rising time	Trise	4		20	ns	
DP/DM falling time	Tfall	4		20	ns	
DP,DM cross point	Vx	1.3		2.0	V	
V33 output voltage	Vreg	3.2	3.3	3.4	V	

Note: All the USB transceiver characteristics meet USB1.1 spec.