



## GENERAL DESCRIPTION

The TM8725 is an embedded high-performance 4-bit microcomputer with LCD driver. It contains all the necessary functions, such as 4-bit parallel processing ALU, ROM, RAM, I/O ports, timer, clock generator, dual clock operation, Resistance to Frequency Converter(RFC), EL panel driver, LCD driver, look-up table, watchdog timer and key matrix scanning circuitry in a single chip.

## FEATURE

1. Low power dissipation
2. Powerful instruction set (178 instructions).
  - Binary addition, subtraction, BCD adjust, logical operation in direct and index addressing mode.
  - Single-bit manipulation (set, reset, decision for branch).
  - Various conditional branch.
  - 16 working registers and manipulation.
  - Table look-up.
  - LCD driver data transfer.
3. Memory capacity
  - ROM capacity 3072 x 16 bits.
  - RAM capacity 384 x 4 bits.
4. LCD driver output
  - 6 common outputs and 40 segment outputs (up to drive 240 LCD segments).
  - 1/2 Duty, 1/3 Duty, 1/4 Duty, 1/5 Duty or 1/6Duty is selected by MASK option.
  - 1/2 Bias or 1/3 Bias is selected by MASK option.
  - Single instruction to turn off all segments.
  - COM5~6, SEG1~40 could be defined as CMOS or P\_open drain type output by mask option.
5. Input/output ports
  - Port IOA 4 pins (with internal pull-low), muxed with SEG24~SEG27.
  - Port IOB 4 pins (with internal pull-low). muxed with SEG28~SEG31
  - Port IOC 4 pins (with internal pull-low, low-level-hold), muxed with SEG32 ~ SEG35. IOC port had built in the input signal chattering prevention circuitry.
  - Port IOD 4 pins (with internal pull-low), muxed with SEG36 ~ SEG39. IOD port had built in the input signal chattering prevention circuitry.
6. 8 level subroutine nesting.

7. Interrupt function.
  - External factors 4 (INT pin, Port IOC, IOD & KI input).
  - Internal factors 4 (Pre-Divider, Timer1, Timer2 & RFC).
8. Built-in EL-light driver
  - ELC, ELP (Muxed with SEG28, SEG29).
9. Built in Alarm, clock or single tone melody generator
  - BZB, BZ (Muxed with SEG30, SEG31).
10. Built-in resistance to frequency converter
  - CX, RR, RT, RH (Muxed with SEG24 ~ SEG27)
11. Built in key matrix scanning function
  - K1~K16 (Shared with SEG1~SEG16).
12. KI1~KI4 (Muxed with SEG32 ~ SEG35)
13. Two 6-bit programmable timer with programmable clock source.
14. Watch dog timer.
15. Built-in Voltage doubler, halver, tripler charge pump circuit.
16. Dual clock operation
  - slow clock oscillation can be defined as X'tal or external RC type oscillator by mask option.
  - fast clock oscillation can be defined as 3.58MHz ceramic resonator, internal R or external R type oscillator by mask option.
17. HALT function.
18. STOP function.

## APPLICATION

- Timer / Calendar / Calculator / Thermometer

**BLOCK DIAGRAM**

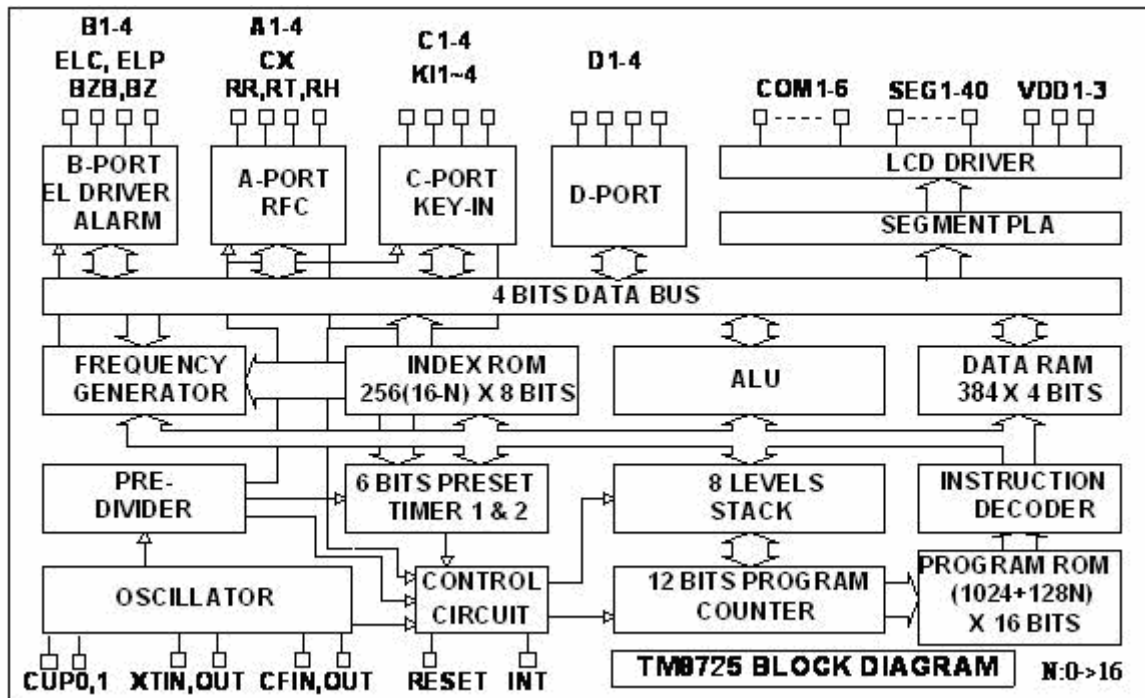

**PAD DIAGRAM**

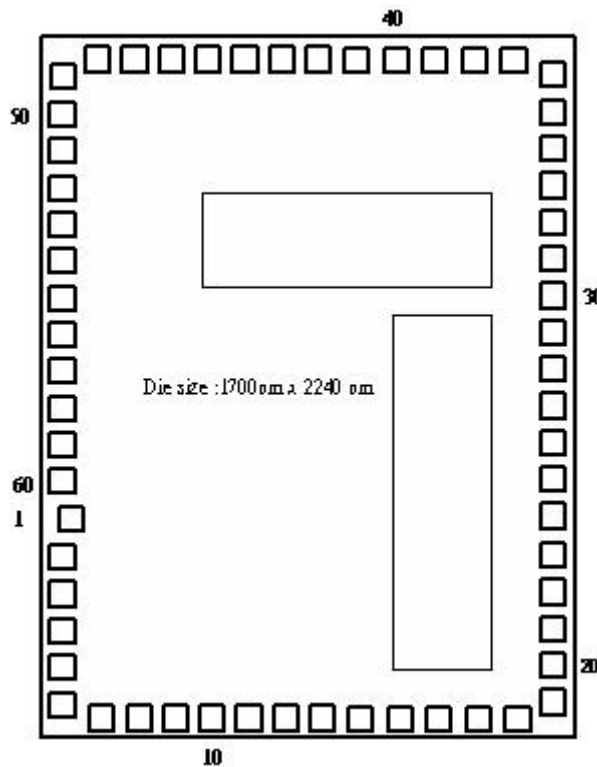

The substrate of chip should be connected to GND.

## PAD COORDINATE

No	Name	X	Y	No	Name	X	Y
1	BAK	99.35	717.50	31	SEG14(K14)	1627.50	1522.50
2	XIN	72.50	602.50	32	SEG15(K15)	1627.50	1637.50
3	XOUT	72.50	487.50	33	SEG16(K16)	1627.50	1752.50
4	CFIN	72.50	372.50	34	SEG17	1627.50	1867.50
5	CFOUT	72.50	247.50	35	SEG18	1627.50	1992.50
6	GND	72.50	122.50	36	SEG19	1627.50	2117.50
7	VDD1	197.50	72.50	37	SEG20	1502.50	2167.50
8	VDD2	322.50	72.50	38	SEG21	1377.50	2167.50
9	VDD3	447.50	72.50	39	SEG22	1252.50	2167.50
10	CUP1	562.50	72.50	40	SEG23	1137.50	2167.50
11	CUP2	677.50	72.50	41	SEG24/IOA1/CX	1022.50	2167.50
12	COM1	792.50	72.50	42	SEG25/IOA2/RR	907.50	2167.50
13	COM2	907.50	72.50	43	SEG26/IOA3/RT	792.50	2167.50
14	COM3	1022.50	72.50	44	SEG27/IOA4/RH	677.50	2167.50
15	COM4	1137.50	72.50	45	SEG28/IOB1/ELC	562.50	2167.50
16	COM5	1252.50	72.50	46	SEG29/IOB2/ELP	447.50	2167.50
17	COM6	1377.50	72.50	47	SEG30/IOB3/BZB	322.50	2167.50
18	SEG1(K1)	1502.50	72.50	48	SEG31/IOB4/BZ	197.50	2167.50
19	SEG2(K2)	1627.50	122.50	49	SEG32/IOC1/K11	72.50	2117.50
20	SEG3(K3)	1627.50	247.50	50	SEG33/IOC2/K12	72.50	1992.50
21	SEG4(K4)	1627.50	372.50	51	SEG34/IOC3/K13	72.50	1867.50
22	SEG5(K5)	1627.50	487.50	52	SEG35/IOC4/K14	72.50	1752.50
23	SEG6(K6)	1627.50	602.50	53	SEG36/IOD1	72.50	1637.50
24	SEG7(K7)	1627.50	717.50	54	SEG37/IOD2	72.50	1522.50
25	SEG8(K8)	1627.50	832.50	55	SEG38/IOD3	72.50	1407.50
26	SEG9(K9)	1627.50	947.50	56	SEG39/IOD4	72.50	1292.50
27	SEG10(K10)	1627.50	1062.50	57	SEG40	72.50	1177.50
28	SEG11(K11)	1627.50	1177.50	58	RESET	72.50	1062.50
29	SEG12(K12)	1627.50	1292.50	59	INT	72.50	947.50
30	SEG13(K13)	1627.50	1407.50	60	TEST	72.50	832.50

## PIN DESCRIPTION

Name	I/O	Description
BAK	P	Positive Back-up voltage. At Li power mode, connect a 0.1u capacitor to GND.
VDD1,2,3	P	LCD supply voltage, and positive supply voltage. In Ag Mode, connect positive power to VDD1. In Li or ExtV power mode, connect positive power to VDD2.
RESET	I	Input pin for external reset request signal, built-in internal pull-down resistor.
INT	I	Input pin for external INT request signal. Falling edge or rising edge triggered is defined by mask option. Internal pull-down or pull-up resistor is defined by mask option.
TEST		Test signal input pin.
CUP1,2	O	Switching pins for supply the LCD driving voltage to the VDD1, 2, 3 pins. Connect the CUP1 and CUP2 pins with non-polarized electrolytic capacitors when chip operated in 1/2 or 1/3 bias mode. In no BIAS mode application, leave these pins opened.
XIN XOUT	I O	Time base counter frequency (clock specified. LCD alternating frequency. Alarm signal frequency) or system clock oscillation. The usage of 32KHz Crystal oscillator or external RC oscillator is defined by mask option.
CFIN CFOUT	I O	System clock oscillation for FAST clock only or DUAL clock operation. The usage of 3.58MHz ceramic/resonator oscillator or external R type oscillator is defined by mask option
COM1~6	O	Output pins for driving the common pins of the LCD panel. COM5~6 could be defined as COMS or Open Drain type output.
SEG1-40	O	Output pins for driving the LCD panel segment.
IOA1-4	I/O	Input / Output port A, (muxed with SEG24~27)
IOB1-4	I/O	Input / Output port B, (muxed with SEG28~31)
IOC1-4	I/O	Input / Output port C, (muxed with SEG32~35)
IOD1~4	I/O	Input / Output port D, (muxed with SEG36~39)
CX RR/RT/RH	I O	1 input pin and 3 output pins for RFC application. (muxed with SEG24~27)
ELC/ELP	O	Output port for EI panel driver. (muxed with SEG28~29)
BZB/BZ	O	Output port for alarm, clock or single tone melody generator. (muxed with SEG30~31)
K1~16	O	Output port for key matrix scanning.(Shared with SEG1~SEG16)
KI1~4	I	Input port for key matrix scanning.(Muxed with SEG32~SEG35)
GND	P	Negative supply voltage.

**ABSOLUTE MAXIMUM RATINGS**

GND= 0V

Name	Symbol	Range	Unit
Maximum Supply Voltage	VDD1	-0.3 to 5.5	V
	VDD2	-0.3 to 5.5	V
	VDD3	-0.3 to 8.5	V
Maximum Input Voltage	Vin	-0.3 to VDD1/2+0.3	V
Maximum output Voltage	Vout1	-0.3 to VDD1/2+0.3	V
	Vout2	-0.3 to VDD3+0.3	V
Maximum Operating Temperature	Topg	-40 to +80	°C
Maximum Storage Temperature	Tstg	-50 to +125	°C

**POWER CONSUMPTION**

at Ta=-20°C to 70°C, GND= 0V

Name	Sym.	Condition	Min.	Typ.	Max.	Unit
HALT mode	IHALT1	Only 32.768KHz Crystal oscillator operating, without loading. Ag mode, VDD1=1.5V, BCF = 0		2		uA
	IHALT2	Only 32.768KHz Crystal oscillator operating, without loading. Li mode, VDD2=3.0V, BCF = 0		2		uA
STOP mode	ISTOP				1	uA

**Note:** When RC oscillator function is operating, the current consumption will depend on the frequency of oscillation.

**ALLOWABLE OPERATING CONDITIONS**

at Ta=-20°C to 70°C, GND= 0V

Name	Symb.	Condition	Min.	Max.	Unit
Supply Voltage	VDD1		1.2	5.25	V
	VDD2		2.4	5.25	V
	VDD3		2.4	8.0	V
Oscillator Start-Up Voltage	VDDDB	Crystal Mode	1.3		V
Oscillator Sustain Voltage	VDDDB	Crystal Mode	1.2		V
Supply Voltage	VDD1	Ag Mode	1.2	1.8	V
Supply Voltage	VDD2	EXT-V, Li Mode	2.4	5.25	V
Input "H" Voltage	Vih1	Ag Battery Mode	VDD1-0.7	VDD1+0.7	V
Input "L" Voltage	Vil1		-0.7	0.7	V
Input "H" Voltage	Vih2	Li Battery Mode	VDD2-0.7	VDD2+0.7	V
Input "L" Voltage	Vil2		-0.7	0.7	V
Input "H" Voltage	Vih3	OSCIN at Ag Battery Mode	0.8xVDD1	VDD1	V
Input "L" Voltage	Vil3		0	0.2xVDD1	V
Input "H" Voltage	Vih4	OSCIN at Li Battery Mode	0.8xVDD2	VDD2	V
Input "L" Voltage	Vil4		0	0.2xVDD2	V
Input "H" Voltage	Vih5	CFIN at Li Battery or EXT-V Mode	0.8xVDD2	VDD2	V
Input "L" Voltage	Vil5		0	0.2xVDD2	V
Input "H" Voltage	Vih6	RC Mode	0.8xVDDO	VDDO	V
Input "L" Voltage	Vil6		0	0.2xVDDO	V
Operating Freq	Fopg1	Crystal Mode	32		KHZ
	Fopg2	RC Mode	10	1000	KHZ
	Fopg3	CF Mode	1000	3580	KHZ

**INTERNAL RC FREQUENCY RANGE**

Option Mode	BAK	Min.	Typ.	Max.
250KHz	1.5V	300KHz	350KHz	400KHz
	3.0V	200KHz	250KHz	300KHz
500KHz	1.5V	500KHz	600KHz	700KHz
	3.0V	400KHz	500KHz	600KHz

**ELECTRICAL CHARACTERISTICS**

at#1:VDD1=1.2V(Ag);

at#2:VDD2=2.4V(Li);

at#3:VDD2=4V(Ext-V);

**Input Resistance**

Name	Symb.	Condition	Min.	Typ.	Max.	Unit
"L" Level Hold Tr(IOC)	Rllh1	Vi=0.2VDD1,#1	10	40	100	Kohm
	Rllh2	Vi=0.2VDD2,#2	10	40	100	Kohm
	Rllh3	Vi=0.2VDD2,#3	5	20	50	Kohm
IOC Pull-Down Tr	Rmad1	Vi=VDD1,#1	200	500	1000	Kohm
	Rmad2	Vi=VDD2,#2	200	500	1000	Kohm
	Rmad3	Vi=VDD2,#3	100	250	500	Kohm
INT Pull-up Tr	Rintu1	Vi=VDD1,#1	200	500	1000	Kohm
	Rintu2	Vi=VDD2,#2	200	500	1000	Kohm
	Rintu3	Vi=VDD2,#3	100	250	500	Kohm
INT Pull-Down Tr	Rintd1	Vi=GND,#1	200	500	1000	Kohm
	Rintd2	Vi=GND,#2	200	500	1000	Kohm
	Rintd3	Vi=GND,#3	100	250	500	Kohm
RES Pull-Down R	Rres1	Vi=GND or VDD1,#1	10	50	100	Kohm
	Rres2	Vi=GND or VDD2,#2	10	50	100	Kohm
	Rres3	Vi=GND or VDD2,#3	10	50	100	Kohm

**DC Output Characteristics**

Name	Symb.	Condition	Port	Min.	Typ.	Max.	Unit
Output "H" Voltage	Voh1c	Ioh=-200uA,#1	COM5~6 SEG1~40	0.8	0.9	1.0	V
	Voh2c	Ioh=-1mA,#2		1.5	1.8	2.1	V
	Voh3c	Ioh=-3mA,#3		2.5	3.0	3.5	V
Output "L" Voltage	Vol1c	Iol=400uA,#1		0.2	0.3	0.4	V
	Vol2c	Iol=2mA,#2		0.3	0.6	0.9	V
	Vol3c	Iol=6mA,#3		0.5	1.0	1.5	V

## Segment Driver Output Characteristics

Name	Symb.	Condition	For	Min.	Typ.	Max.	Unit.
<b>Static Display Mode</b>							
Output "H" Voltage	Voh1d	Ioh=-1uA,#1	SEG-n	1.0			V
	Voh2d	Ioh=-1uA,#2		2.2			V
	Voh3d	Ioh=-1uA,#3		3.8			V
Output "L" Voltage	Vol1d	Iol=1uA,#1				0.2	V
	Vol2d	Iol=1uA,#2				0.2	V
	Vol3d	Iol=1uA,#3				0.2	V
Output "H" Voltage	Voh1e	Ioh=-10uA,#1	COM-n	1.0			V
	Voh2e	Ioh=-10uA,#2		2.2			V
	Voh3e	Ioh=-10uA,#3		3.8			V
Output "L" Voltage	Vol1e	Iol=10uA,#1				0.2	V
	Vol2e	Iol=10uA,#2				0.2	V
	Vol3e	Iol=10uA,#3				0.2	V
<b>1/2 Bias Display Mode</b>							
Output "H" Voltage	Voh12f	Ioh=-1uA,#1,#2	SEG-n	2.2			V
	Voh3f	Ioh=-1uA,#3		3.8			V
Output "L" Voltage	Vol12f	Iol=1uA,#1,#2				0.2	V
	Vol3f	Iol=1uA,#3				0.2	V
Output "H" Voltage	Voh12g	Ioh=-10uA,#1,#2	COM-n	2.2			V
	Voh3g	Ioh=-10uA,#3		3.8			V
Output "M" Voltage	Vom12g	Iol/h=+/-10uA,#1,#2	COM-n	1.0		1.4	V
	Vom3g	Iol/h=+/-10uA,#3		1.8		2.2	V
<b>1/3 Bias display Mode</b>							
Output "H" Voltage	Voh12h	Ioh=-1uA,#1,#2	SEG-n	3.4			V
	Voh3h	Ioh=-1uA,#3		5.8			V
Output "M1" Voltage	Vom1h	Iol/h=+/-10uA,#1,#2		1.0		1.4	V
	Vom13h	Iol/h=+/-10uA,#3		1.8		2.2	V
Output "M2" Voltage	Vom22h	Iol/h=+/-10uA,#1,#2		2.2		2.6	V
	Vom23h	Iol/h=+/-10uA,#3		3.8		4.2	V
Output "L" Voltage	Vol12h	Iol=1uA,#1,#2			0.2	V	
	Vol3h	Iol=1uA,#3			0.2	V	
Output "H" Voltage	Voh12i	Ioh=-10uA,#1,#2	COM-n	3.4			V
	Voh3i	Ioh=-10uA,#3		5.8			V
Output "M1" Voltage	Vom12i	Iol/h=+/-10uA,#1,#2		1.0		1.4	V
	Vom13i	Iol/h=+/-10uA,#3		1.8		2.2	V
Output "M2" Voltage	Vom22i	Iol/h=+/-10uA,#1,#2		2.2		2.6	V
	Vom23i	Iol/h=+/-10uA,#3		3.8		4.2	V
Output "L" Voltage	Vol12i	Iol=10uA,#1,#2			0.2	V	
	Vol3i	Iol=10uA,#3			0.2	V	

**TYPICAL APPLICATION CIRCUIT**

This application circuit is simply an example, and is not guaranteed to work.

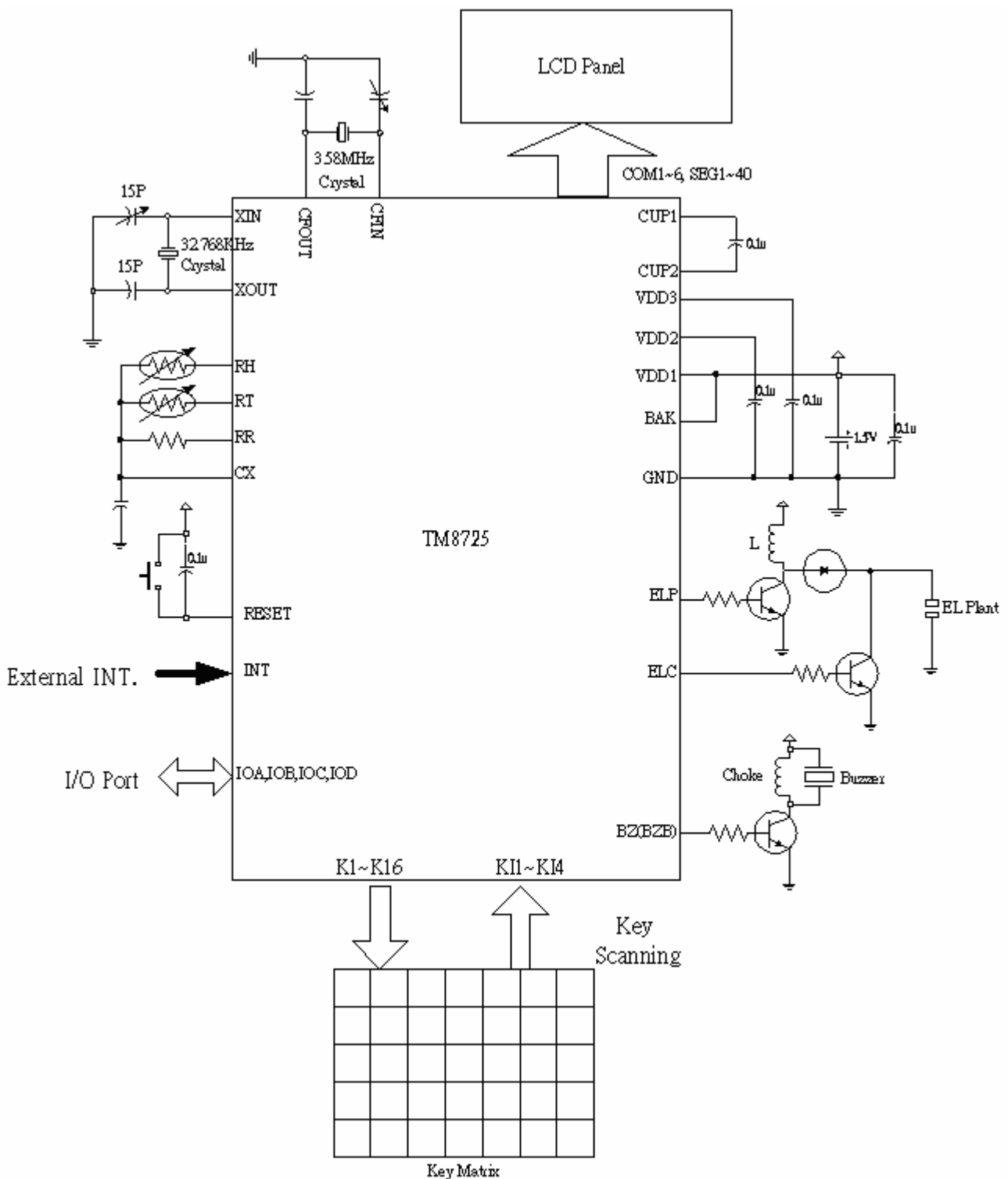

**Ag power mode, 1/3 Bias, 1/6 Duty**