



GENERAL DESCRIPTION

The TP6904 is an 8-bit micro-controller embedded device tailored to the USB audio application. It is able to play two channels PC audio through Full-Speed USB bus.

FEATURE

- Compliance with the Universal Serial Bus specification v2.0 Full-Speed
- Built-in USB Transceiver & 3.3V Regulator
- Isochronous transfer with adaptive synchronization
- High performance 48KHz sampling rate for audio playback
- Two channel audio Class-D Amplify for speaker driving
- 64-level volume control, 2.1ch balance volume control
- Support USB Suspend function
- 24MHz crystal oscillation
- 28 pin package

BLOCK DIAGRAM

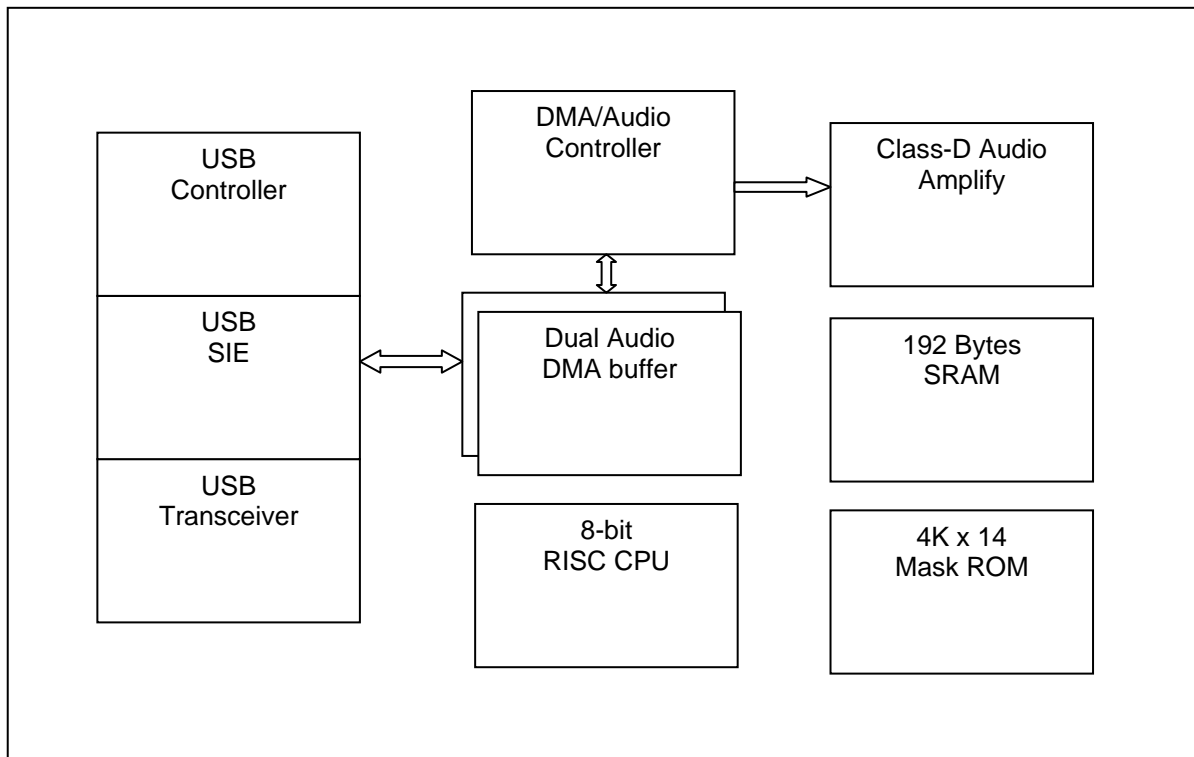

PIN DESCRIPTION

Name	I/O	Description
V33	O	3.3V Regulator output
VSS	P	Ground
VDD	P	5V Power from USB cable
ADC	I	VR input for volume adjustment
X1	I	Crystal in (24MHz)
X2	O	Crystal out
RESETn	I	Chip reset (active low)
TESTn	I	Test Mode control (active low)
DP	I/O	USB positive data signal
DM	I/O	USB negative data signal
AVDD	P	5V Power for Audio output
AVSS	P	Ground for Audio output
AUDIOLP	O	Audio output
AUDIOLN	O	Audio output
AUDIORP	O	Audio output
AUDIORN	O	Audio output
PB[7:0]	I/O	General purpose I/O (Pseudo Open Drain)

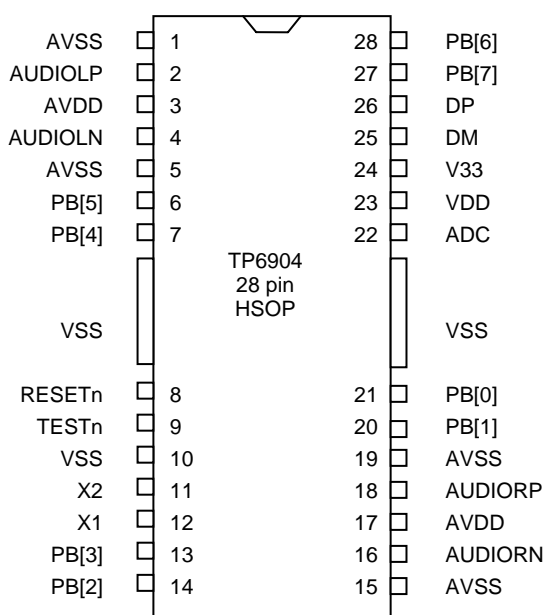
PIN ASSIGNMENT

APPLICATION CIRCUIT

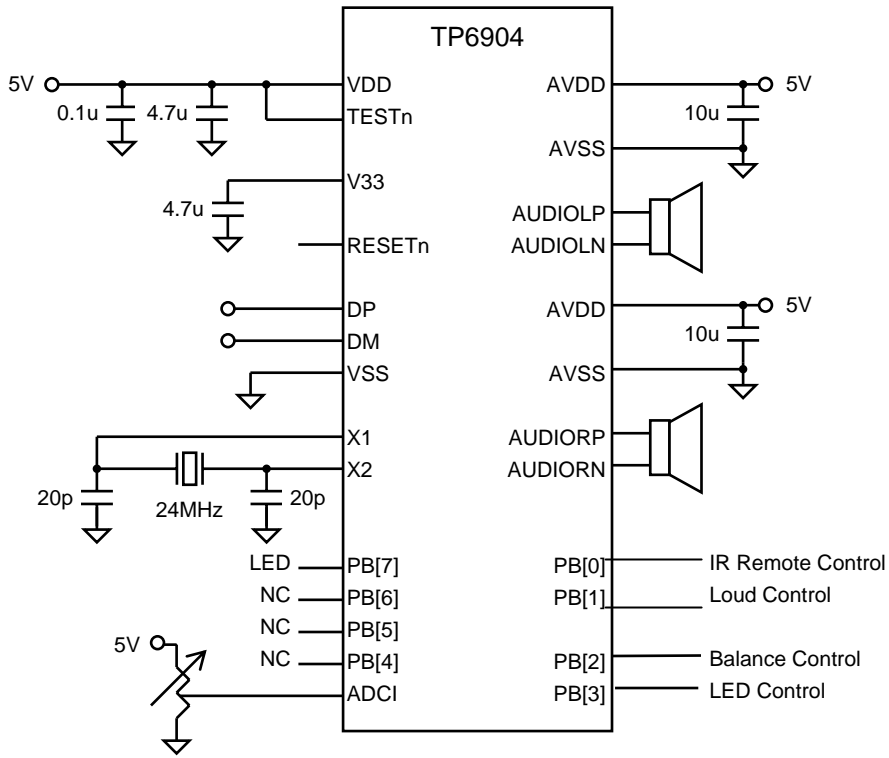

ABSOLUTE MAXIMUM RATINGS

GND= 0V

Name	Symbol	Range	Unit
Maximum Supply Voltage	VDD	-0.3 to 5.5	V
Maximum Input Voltage	Vin	-0.3 to VDD+0.3	V
Maximum output Voltage	Vout	-0.3 to VDD+0.3	V
Maximum Operating Temperature	Topg	-20 to +70	°C
Maximum Storage Temperature	Tstg	-25 to +125	°C

OPERATING CONDITION

at Ta= -20°C to 70°C, GND= 0V

Name	Symb.	Min.	Typ.	Max.	Unit
Supply Voltage	VDD5	4.5		5.5	V
Input "H" Voltage	Vih	4.0		5.5	V
Input "L" Voltage	Vil	0		0.8	V
Crystal frequency	Fosc		24		MHz

ELECTRICAL PARAMETER

at Ta= -20°C to 70°C, GND= 0V

Name	Symb.	Typ	Unit
Maximum Audio Output Current per Channel @ 4ohm Load	Iout	400	mA
Maximum Audio Output Current per Channel @ 8ohm Load	Iout	346	mA

DC ELECTRICAL CHARACTERISTICS:

at Ta=-25 °C, VDD5=5.0V, VSS= 0V, Fosc=24MHz

Name	Symb.	Min.	Typ.	Max.	Unit	Condition	Note
Operating current	Icc		40		mA	Fosc=24MHz	Audio playing
Suspend current	Isus		300		uA		
PB Output High Voltage	Vboh1		4.5		V	Ioh=4mA	Only one clock time
	Vboh2		4.0		V	Ioh=40uA	
PB Output Low Voltage	Vbol		0.4		V	Iol=10mA	
Audio Output High Voltage		4.0			V	Ioh=200mA	Max. scale volume
Audio Output Low Voltage				0.8	V	Iol=200mA	Max. scale volume
V33 output voltage	V3o	3.2		3.4	V	VDD5=5V	

