



十速科技股份有限公司
tenx technology inc.

**Advance
Information**

TP66P04

USB & PS2 Keyboard Controller

Data Sheet

**Tenx reserves the right to change or
discontinue this product without notice.**

tenx technology inc.

tenx technology, inc.

Preliminary

Rev 1.5, 2010/02/08

CONTENTS

General Description	2
FEATURES	2
PIN DESCRIPTION	3
Pin Assignment	3
PS2 Timing Diagram	4
PS2 Command Descriptions	6
KEY MATRIX DEFINITION (TP66P04)	8
APPLICATION CIRCUIT	9
ABSOLUTE MAXIMUM RATINGS	10
RECOMMEND OPERATING CONDITION	10
DC CHARACTERISTICS	10
AC CHARACTERISTICS	10
Package Diagrams	11
PAD locations	13
Ordering Information	14

General Description

The TP66P04 is an 8-bit microprocessor embedded device tailored to the USB/PS2 Keyboard application. It supports all the 3 sets of scan code in PS2 mode and meets all the configurations of USB 1.1. The chip has a built-in regulator which will can minimize the external parts. The OTP type of MCU will reduce the risk of mass production and stock.

FEATURES

- Compliance with the Universal Serial Bus specification v1.1
- Built-in USB Transceiver and 3.3V regulator
- Support USB Suspend and Resume function
- Support HID usage ID for USB
- PS2 compatible keyboard interface share with USB interface
- Support IBM PC AT PS2 keyboard
- Support IBM PC AT USB keyboard
- Built-in internal pull-up resistors
- Built-in 8K OTP ROM
- 3MHz instruction rate with 6MHz crystal oscillation
- Support Windows 95, 98, 2000, ME, XP
- Support 104/107 key, many multi-media keys and some other special function keys
- 40/48 pin package

PIN DESCRIPTION

Name	I/O	Description
VDD	P	5V Power from USB cable
VSS	P	Ground
X1	I	Crystal in (6MHz)
X2	O	Crystal out
RESETn	I	Chip reset (active low)
TESTn	I	Test Mode control (active low)
DP/Clock	I/O	USB positive data signal / PS2 CLOCK signal
DM/Data	I/O	USB negative data signal / PS2 DATA signal
KSI[7:0]	I	Key scan input (with built-in pull-up resistor)
KSO[15:0]	O	Key scan output (open drain with pull up resistor)
PA[3:0]	I/O	General purpose I/O (open drain with pull up resistor)
PB[1:0]	I/O	General purpose I/O (pseudo open-drain)
LED[3:0]	O	LED output (with serial 450 ohm resistor)
VPP	I	OTP programming power
V33	O	3.3V regulator output

Pin Assignment

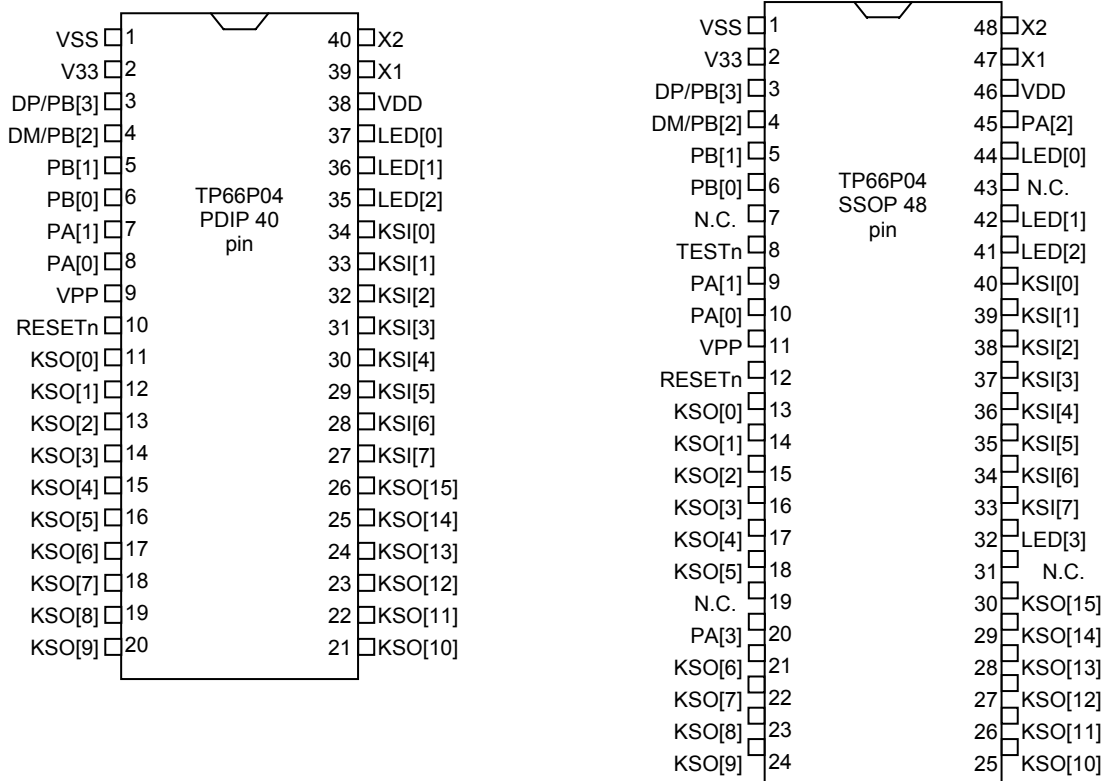

PS2 Timing Diagram

Keyboard output data timings

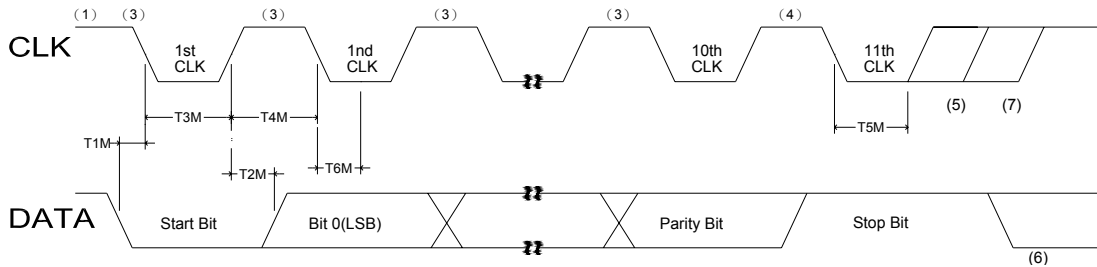

	Timing Parameter	Min.	Max.
T1M	Time from DATA transition to falling edge of CLK	5 us	25 us
T2M	Time from rising edge of CLK to DATA transition	5 us	T4M –5us
T3M	Duration of CLK inactive (low)	30 us	50 us
T4M	Duration of CLK active (high)	30 us	50 us
T5M	Time to auxiliary device inhibit after clock 11 to ensure the auxiliary device does not start another transmission	> 0 us	> 50 us
T6M	Time from inactive to active CLK transition, used to time when auxiliary device samples DATA	5 us	25 us

Keyboard input data timings

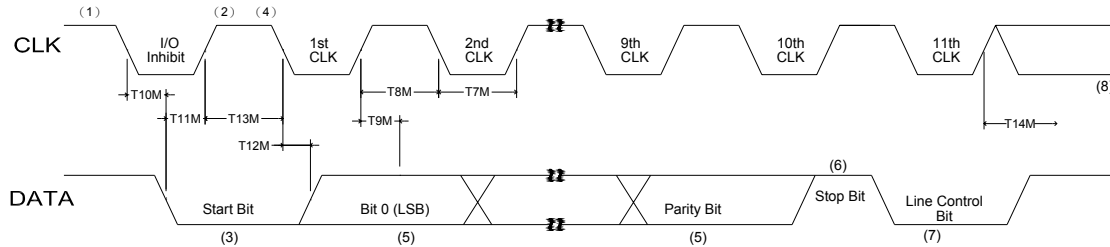

	Timing Parameter	Min.	Max.
T7M	Duration of CLK inactive (low)	30 us	50 us
T8M	Duration of CLK active (high)	30 us	50 us
T9M	Time from inactive to active CLK transition, used to time when the auxiliary device samples DATA	5 us	25 us
T10M	Time from CLK inhibit to start bit inactive		
T11M	Time from start bit inactive to CLK active		
T12M	Time from CLK falling edge of DATA transition		
T13M	Transmit response time	0 us	10 us
T14M	Receive Timeout (Time to auxiliary device response)	0 us	25 us

PS2 Command Descriptions

Commands from the system to Keyboard

The following commands may be sent from the system to the keyboard:

Set /Reset Status indicators (Hex ED)

This command is used to activate or deactivate the three LEDs on the TP66P04 from the system.

Echo (Hex EEH)

This command is used as a diagnostic aid, testing the keyboard command process.

Invalid commands (Hex EF and F1)

Return a RESEND command and continues in its previous scanning state.

Select Alternate Scan Codes (Hex F0)

This command instructs the keyboard to select scan codes.

Option byte =

02 : select scan code set 2

Read ID (F2)

TP66P04 will send two ID bytes. The second byte will be sent within 500 uS after first byte.

Set Typematic Rate/Delay (Hex F3)

This command is used to set the typematic rate and delay.

1. Typematic rate = $1/T \pm 20\%$
Repeat period = $(8+A) \times (2^B) \times 0.00417$ seconds
A : binary value of bits 2, 1, and 0.
B : binary value of bits 4 and 3.
Default = 10.9 characters per second
2. Delay = $(1+C) \times 250 \text{ ms} \pm 20\%$
C : binary value of bits 6 and 5.
Default = 500 ms

Enable (Hex F4)

Opposite of the Default Disable.

Default Disable (Hex F5)

Upon receiving this command, the TP66P04 stops scanning operation and waits for further instructions from the system.

Set Default (Hex F6)

The TP66P04 resets all the conditions previously set to the power-on default state.

Set All Keys (Hex F7, F8, F9, FA)

Clear output buffer.

Set all key type (affect only scan code set 3 operation).

F7 : Typematic

F8 : Make/Break

F9 : Make

FA : Typematic/Make/Break

Return to previous scanning rate.

Set Key Type (Hex FB, FC, FD)

Clear output buffer.
Receive key ID byte
Response ACK
Set key ID type (affect only scan code set 3 operation).
 FB : Typematic Make/Break
 FD : Make
Return to previous scanning rate.

Resend (Hex FE)

Send the previous output again.

Reset (Hex FF)

The TP66P04 sends AA to the system, clears the output buffer, and sets up the default values for the typematic rates.

Command from keyboard to the system

The following commands are sent from the TP66P04 to the system:

Acknowledge (Hex FA)

The keyboard sends an acknowledge in response to any valid command from the system besides an RESEND or ECHO.

BAT Completion Code (Hex AA)

This command is issued after successful completion of keyboard self test.

Echo (Hex EE)

This command is used to response to the Echo command.

Keyboards ID (Hex 83AB)

The two byte ID is issued to respond to READ ID command. The low byte is sent first, followed by the high byte.

Keyboard buffer Overrun (Hex 00 or FF)

If keyboard buffer overflows, the overrun code will replace the last byte in the buffer. For scan code sets 2, the code is hex 00.

KEY MATRIX DEFINITION (TP66P04)

	<i>KSI7</i>	<i>KSI6</i>	<i>KSI5</i>	<i>KSI4</i>	<i>KSI3</i>	<i>KSI2</i>	<i>KSI1</i>	<i>KSI0</i>
<i>KSO13</i>	Pause	Power		Sleep	R_Ctrl	Wake Up	L_Ctrl	F5
<i>PA1</i>	Q	TAB	A	Esc	Z	(K131)	~ `	! 1
<i>PA0</i>	W	Caps Lock	S	(K45)	X	(K132)	F1	@ 2
<i>KSO0</i>	E	F3	D	F4	C	(K133)	F2	# 3
<i>KSO1</i>	R	T	F	G	V	B	% 5	\$ 4
<i>KSO2</i>	U	Y	J	H	M	N	^ 6	& 7
<i>KSO3</i>	I	}]	K	F6	< ,	(K56)	+ =	* 8
<i>KSO4</i>	O	F7	L		> .	App	F8	(9
<i>KSO11</i>	P	{ [: ;	" '	\	? /	- -) 0
<i>KSO12</i>	Scroll Lock			L_ALT		R_ALT		Print Screen
<i>KSO10</i>	(K14)	Back Space	\	F11	Enter	F12	F9	F10
<i>KSO8</i>	KP 7	KP 4	KP 1	Space	Num Lock	Down	Delete	Power
<i>KSO7</i>	KP 8	KP 5	KP 2	KP 0	KP /	Right	Insert	Sleep
<i>KSO6</i>	KB 9	KP 6	KP 3	KP .	KP *	KP -	Page Up	Page Down
<i>KSO5</i>	KP +	(K107)	KP ENTER	Up	Media Play	Left	Home	End
<i>KSO9</i>	WakeUp	L_Shift	R_Shift	Volume--	Volume +	Media Next	Media Previous	Media
<i>KSO14</i>	www Mail	L_Win	www forward	Www Stop	www Back	www Refresh	Media Mute	Www Search
<i>KSO15</i>	Kor_L	www Bookmark	R_Win	My Computer	Media Stop	Calculator	www Home	Kor_R

APPLICATION CIRCUIT

40 Pin Package

The circuitry is only for reference.

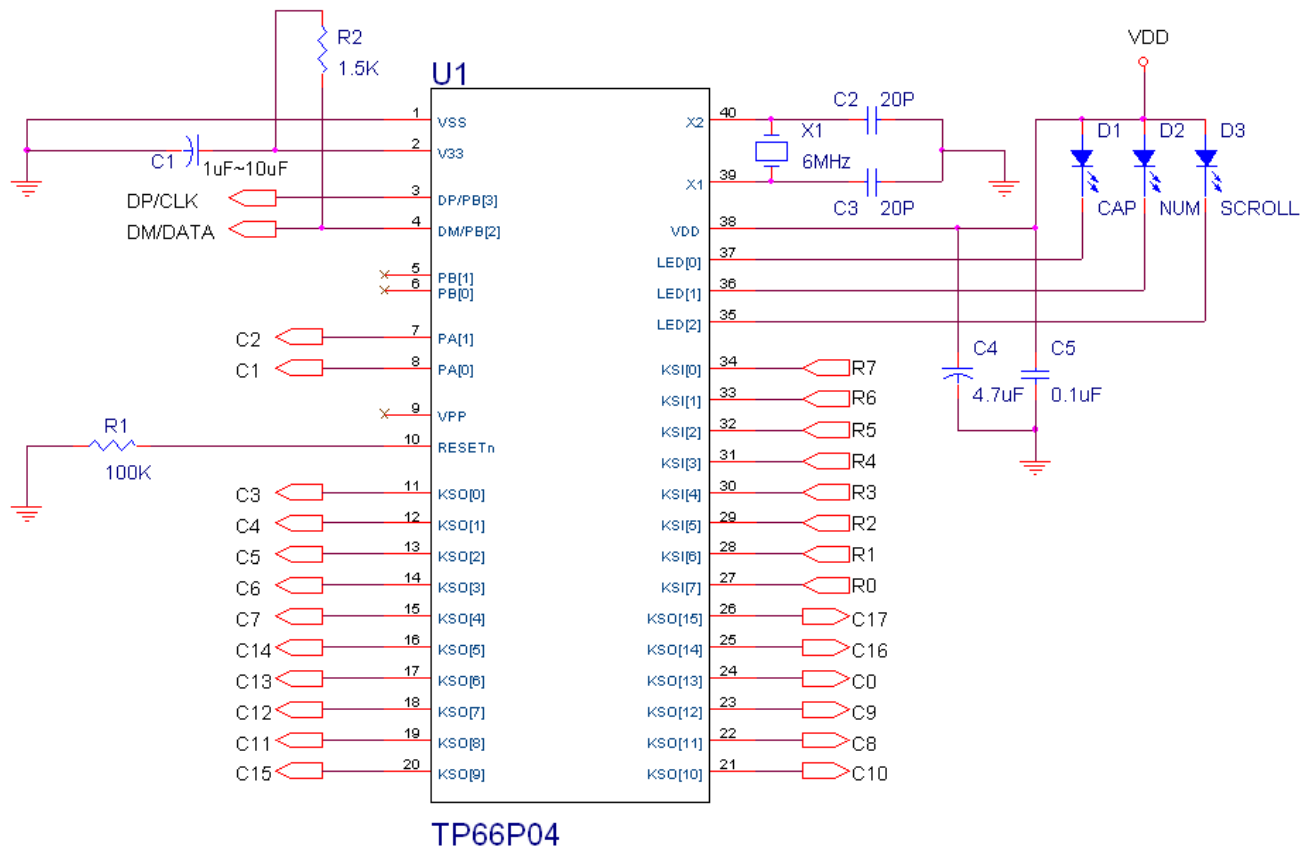

TP66P04

Programming PIN:

VPP , VDD , X1 , RESTn , TESTn , PB [0] , KSI [3] , KSI [6] , KSI [7] , VSS

ABSOLUTE MAXIMUM RATINGS

GND= 0V

Name	Symbol	Range	Unit
Maximum Supply Voltage	VDD	-0.3 to 5.5	V
Maximum Input Voltage	Vin	-0.3 to VDD+0.3	V
Maximum output Voltage	Vout	-0.3 to VDD+0.3	V
Maximum Operating Temperature	Topg	-5 to +70	°C
Maximum Storage Temperature	Tstg	-25 to +125	°C

RECOMMEND OPERATING CONDITION

at Ta=-20°C to 70°C, GND= 0V

Name	Symb.	Min.	Max.	Unit
Supply Voltage	VDD	4.5	5.5	V
Input "H" Voltage	Vih	3.5	5.5	V
Input "L" Voltage	Vil1	0	0.8	V

DC CHARACTERISTICS

at Ta=-25 °C, VDD=5.0V, VSS= 0V, Fosc=6MHz

Name	Symb.	Min.	Typ.	Max.	Unit	Condition
Operating current	Icc		5.5		mA	Fosc=6MHz
Suspend current	Isus		360		uA	No load
Output High Voltage	Voh1		4.0		V	Ioh=30uA
	Voh2		4.5		V	Ioh=4mA
Output Low Voltage	Vol		0.4		V	Iol=15mA
RESET pull up resistor	Rrst		31		Kohm	(Vrst=3.38v)
KSI pull up resistor	Rksi		46		Kohm	
LED sink current	Iled		5.5		mA	Vled=3.2V
V33 output voltage	V33		3.28		V	

AC CHARACTERISTICS

at Ta=-25 °C, VDD=5.0V, VSS= 0V, Fosc=6MHz

Name	Symb.	Min.	Max.	Unit	Note
DP/DM rising time	Trise	75	300	ns	
DP/DM falling time	Tfall	75	300	ns	
DP,DM cross point	Vx	1.3	2.0	V	

Note: All USB transceiver characteristics can meet USB1.1 spec.

Package Diagrams

40 PIN P_DIP

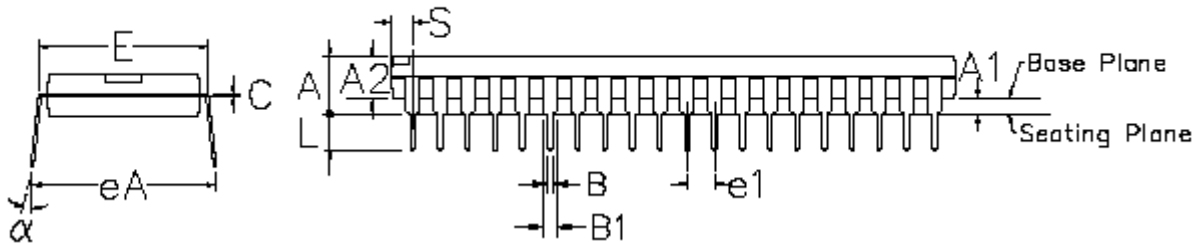
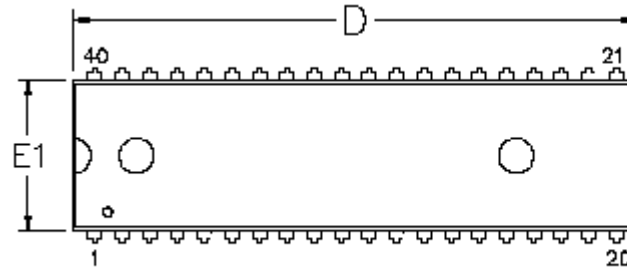

Symbol	Dimension in inch			Dimension in mm		
	Min	Nom	Max	Min	Nom	Max
A	—	—	0.210	—	—	5.33
A1	0.010	—	—	0.25	—	—
A2	0.150	0.155	0.160	3.81	3.94	4.06
B	0.016	0.018	0.022	0.41	0.46	0.56
B1	0.048	0.050	0.054	1.22	1.27	1.37
c	0.008	0.010	0.014	0.20	0.25	0.36
D	—	2.055	2.070	—	52.20	52.58
E	0.590	0.600	0.610	14.99	15.24	15.49
E1	0.540	0.545	0.552	13.72	13.84	14.02
e1	0.090	0.100	0.110	2.29	2.54	2.79
L	0.120	0.130	0.140	3.05	3.30	3.56
α	0°	—	15°	0°	—	15°
eA	0.630	0.650	0.670	16.00	16.51	17.02
S	—	—	0.090	—	—	2.29

48 PIN SSOP

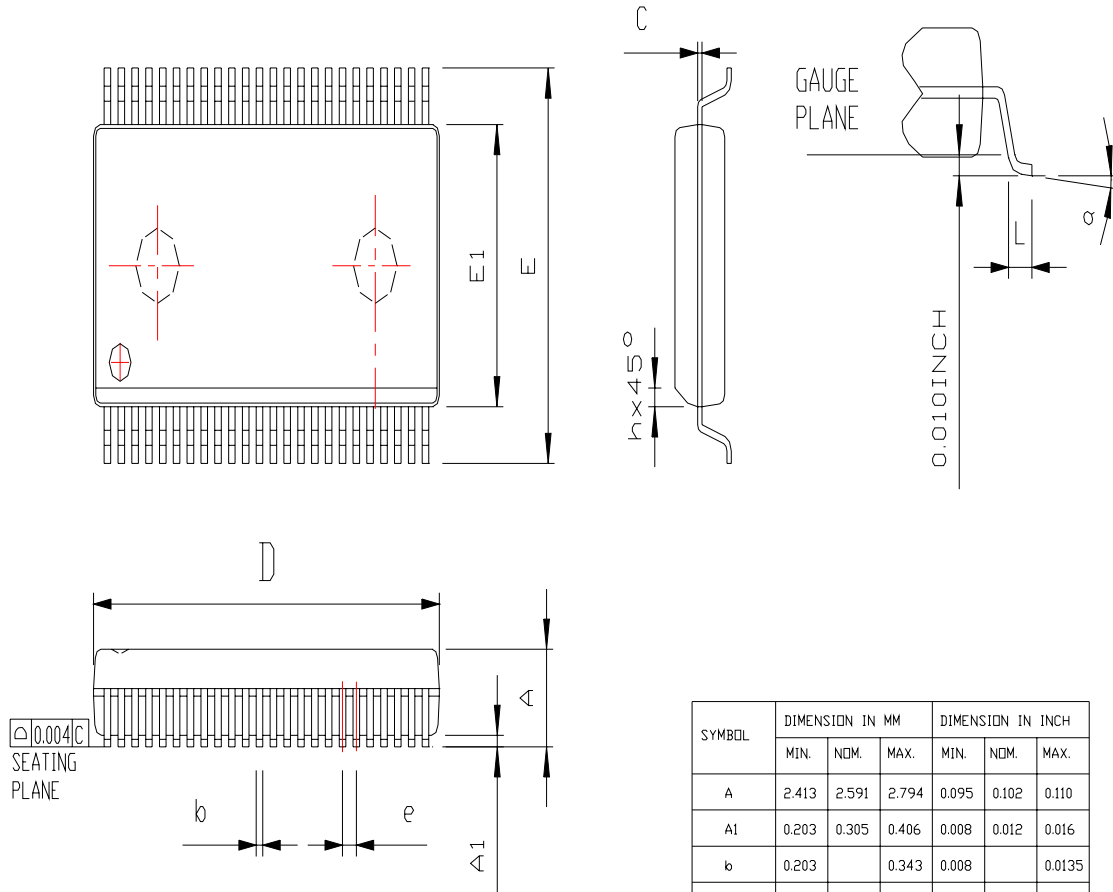

NOTE:

1. DIMENSION "D" DONE NOT INCLUDE MOLD FLASH, PROTRUSIONS OR GATE BURRS.
2. MOLD FLASH, PROTRUSIONS OR GATE BURRS SHALL NOT EXCEED 0.006 INCH(0.1524mm) PER SIDE.

SYMBOL	DIMENSION IN MM			DIMENSION IN INCH		
	MIN.	NOM.	MAX.	MIN.	NOM.	MAX.
A	2.413	2.591	2.794	0.095	0.102	0.110
A1	0.203	0.305	0.406	0.008	0.012	0.016
b	0.203		0.343	0.008		0.0135
c	0.127		0.254	0.005		0.010
e	0.635BASIC			0.025BASIC		
E	10.033		10.668	0.395		0.420
E1	7.391	7.493	7.595	0.291	0.295	0.299
h	0.381		0.635	0.015		0.025
L	0.508		1.016	0.020		0.040
a	0	8	2.473	0		8

N	DIMENSION(IN INCH)			JEDEC
48	0.620	0.625	0.630	MO-118(AA)
56	0.720	0.725	0.730	MO-118(AB)

PAD locations

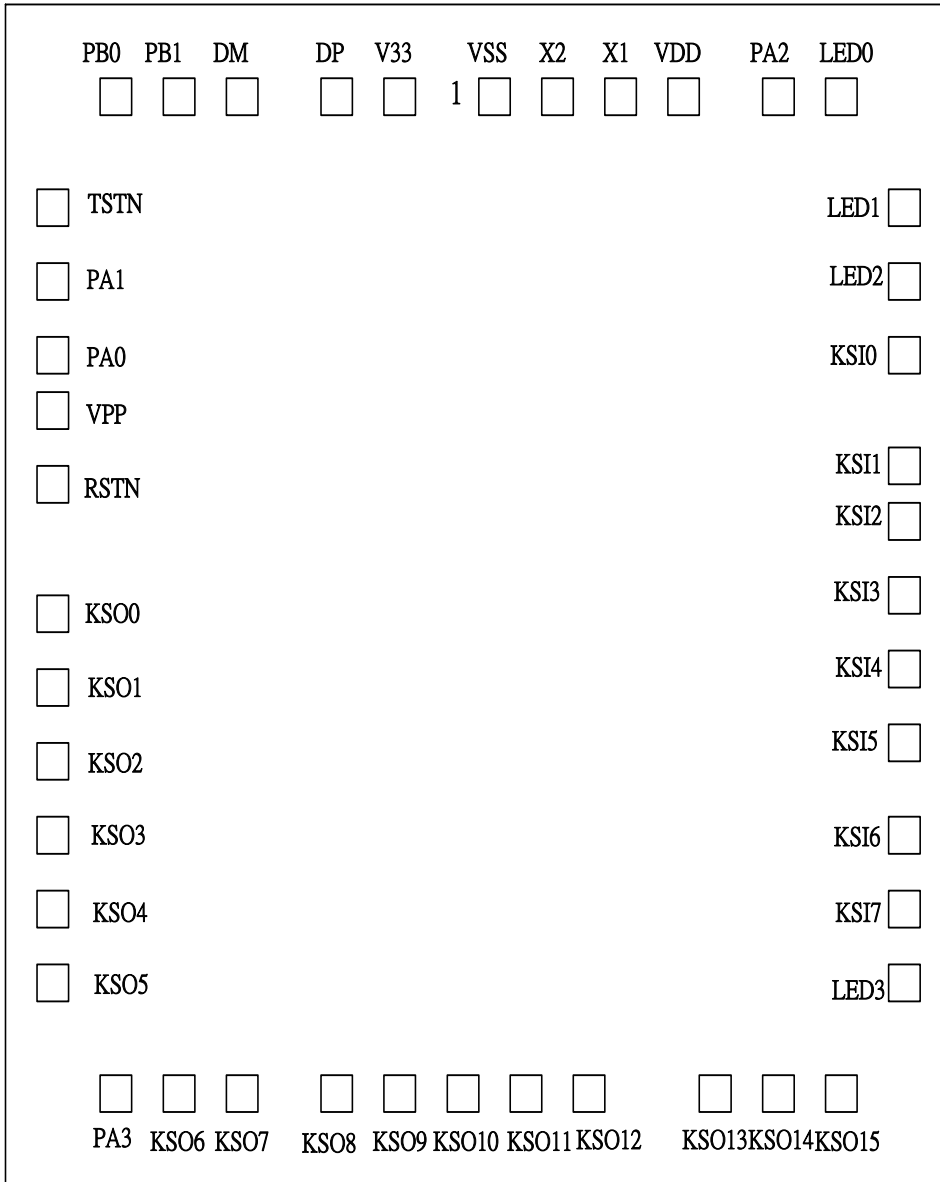

(2170,2130)um

Probe Number	Pad Name	X Coordinate	Y Coordinate	Probe Number	Pad Name	X Coordinate	Y Coordinate
1	VSS	1150.50	2021.00	23	KSO10	1087.50	109.00
2	V33	902.50	2021.00	24	KSO11	1205.50	109.00
3	DP	782.50	2021.00	25	KSO12	1335.50	109.00
4	DM	588.50	2021.00	26	KSO13	1575.50	109.00
5	PB1	467.50	2021.00	27	KSO14	1708.50	109.00
6	PB0	334.50	2021.00	28	KSO15	1829.50	109.00
7	TSTN	109.00	1795.50	29	LED3	2061.00	336.50
8	PA1	109.00	1678.50	30	KS17	2061.00	467.50
9	PA0	109.00	1506.50	31	KS16	2061.00	587.50
10	VPP	109.00	1386.50	32	KS15	2061.00	826.50
11	RSTN	109.00	1246.50	33	KS14	2061.00	946.50
12	KSO0	109.00	1006.5	34	KS13	2061.00	1066.50
13	KSO1	109.00	874.50	35	KS12	2061.00	1186.50
14	KSO2	109.00	754.50	36	KS11	2061.00	1306.50
15	KSO3	109.00	622.50	37	KS10	2061.00	1542.50
16	KSO4	109.00	492.50	38	LED2	2061.00	1662.50
17	KSO5	109.00	334.50	39	LED1	2061.00	1793.50
18	PA3	334.50	109.00	40	LED0	1835.50	2021.00
19	KSO6	467.50	109.00	41	PA2	1714.50	2021.00
20	KSO7	588.50	109.00	42	VDD	1514.50	2021.00
21	KSO8	836.50	109.00	43	X1	1393.50	2021.00
22	KSO9	957.50	109.00	44	X2	1271.50	2021.00

Ordering Information

Ordering Code	Package Type	Operating Range
TP66P04CC	Chip	Commercial
TP66P04DC	40 Pin DIP Package	Commercial
TP66P04SSC	48 Pin SSOP Package	Commercial