

TM89PL59

4-Bit Microcontroller

Data Sheet

tenx reserves the right to change or discontinue the manual and online documentation to this product herein to improve reliability, function or design without further notice. tenx does not assume any liability arising out of the application or use of any product or circuit described herein; neither does it convey any license under its patent rights nor the rights of others. tenx products are not designed, intended, or authorized for use in life support appliances, devices, or systems. If Buyer purchases or uses tenx products for any such unintended or unauthorized application, Buyer shall indemnify and hold tenx and its officers, employees, subsidiaries, affiliates and distributors harmless against all claims, cost, damages, and expenses, and reasonable attorney fees arising out of, directly or indirectly, any claim of personal injury or death associated with such unintended or unauthorized use even if such claim alleges that tenx was negligent regarding the design or manufacture of the part.

AMENDMENT HISTORY

Version	Date	Description
V1.0	May, 2026	New release

CONTENTS

AMENDMENT HISTORY	2
GENERAL DESCRIPTION	4
FEATURES.....	4
APPLICATIONS	6
BLOCK DIAGRAM	6
PAD ASSIGNMENT	7
PIN DESCRIPTION	8
RAM & INITIAL PAGE ASSIGNMENT	9
Configuration of LCD RAM Area.....	11
ABSOLUTE MAXIMUM RATINGS.....	14
POWER CONSUMPTION.....	14
ALLOWABLE OPERATING CONDITIONS	15
ALLOWABLE OPERATING FREQUENCY	15
INTERNAL RC FREQUENCY RANGE	16
ELECTRICAL CHARACTERISTICS	16
TYPICAL APPLICATION CIRCUIT	22
ORDERING INFORMATION	23
Appendix A: TM89PL59 Instruction Table	24
Symbol Description	42
MWM/MMW Rm Assignment.....	43

GENERAL DESCRIPTION

TM89PL59(L/H) is a One Time PROM embedded high-performance 4-bit microcomputer with LCD driver. It contains all the necessary functions, such as 4-bit parallel processing ALU, ROM, RAM, I/O ports, timer, clock generator, dual clock operation, Resistance to Frequency Converter (RFC), EL panel driver, LCD driver, look-up table, watchdog timer and key matrix scanning circuitry in a signal chip.

FEATURES

1. Low power dissipation.

- 1.5V/3V operating voltage range.

TM89PL59L	1.5V Power Mode
TM89PL59H	3V Power Mode

2. Powerful instruction set.

- Binary addition, subtraction, BCD adjustment. BCD can be executed directly in addition/subtraction operations.
- 4 bits x 4 bits Multiplier.
- Single-bit manipulation (set, reset, decision for branch).
- Various conditional branches.
- 16 initial working registers and manipulators (can be extended to all RAM with Page Mode).
- Look-up Table.
- LCD driver data transfer.

3. ROM Capacity(one/two program code)

32/31K x 16 bits.

- Instruction ROM Max. Capacity(one/two program code) 32/31K x 16 bits.
- Table ROM Max. Capacity(one/two program code) 32K/32K x 8 bits.
16/16K x 16 bits.

4. RAM Capacity.

6K / 3K / 1.5K x 4 / 8 / 16 bits.

- LCD Max. Capacity 256 / 128 / 64 x 4 / 8 / 16 bits.
- STACK Max. Capacity 16 x 16 bits.
- HL/ZR store Max. Capacity 16 / 16 x 16 bits.

5. With direct/index addressing mode in data RAM access.

6. LCD driver output.

- 16 common outputs and 64 segment outputs.
- 1/1 ~ 1/16 Duty can be selected by code option.
- No Bias , 1/2 ~ 1/4 Bias can be selected by code option.

- Single instruction to turn off all segments.
- COM2 ~ 16 can be defined as CMOS or P_open drain type output port by code option.
- External/Internal regulator mode for VL1/2 by code option.

7. Input/output ports.

- Port IOA 4 pins (with internal pull-low, input signal chattering prevention circuitry).
- Port IOB 4 pins (with internal pull-low), and can be defined as KI1 ~ 4 by code option.
- Port IOC 4 pins (with internal pull-low, low-level-hold, input signal chattering prevention circuitry).
- Port IOD 4 pins (with internal pull-low, input signal chattering prevention circuitry)
- Port IOE 4 pins (with internal pull-low).

8. Interrupt function.

- External factors 5 (INT pin, Port IOA, IOC, IOD & KI input).
- Internal factors 5 (Pre-Divider, Timer1, Timer2, Timer3 & RFC).

9. Built-in EL-light driver.

- ELC, ELP

10. Built-in Alarm, clock or single tone melody generator.

- BZB, BZ

11. Built-in resistance to frequency converter.

- CX, CX2, RFC0 ~ 5

12. Built-in key matrix scanning function.

- KO1 ~ KO16 (Shared with SEG1 ~ 16)
- KI1 ~ KI4 (Can be defined as IOB1 ~ 4 by code option)

13. Three 6-bit programmable timers with programmable clock source.

- Read the content at any time
- Merge 2 or 3 timers into one 12-bit or 18-bit timer
- Used as a counter for RFC

14. Watchdog timer.**15. Built-in voltage charge halver & pump circuit.****16. Dual clock operation**

- Slow clock oscillation can be defined as X'tal or external RC type oscillator by code option.
- Fast clock oscillation can be defined as 3.58 MHz ceramic resonator, internal R or external R type oscillator by code option.

- 17.HALT function.
- 18.STOP function.
- 19.Built-in Low Battery Detect.
- 20.Built-in Low Voltage Reset(2 type).

APPLICATIONS

- Timer / Calendar / Calculator / Thermometer

BLOCK DIAGRAM

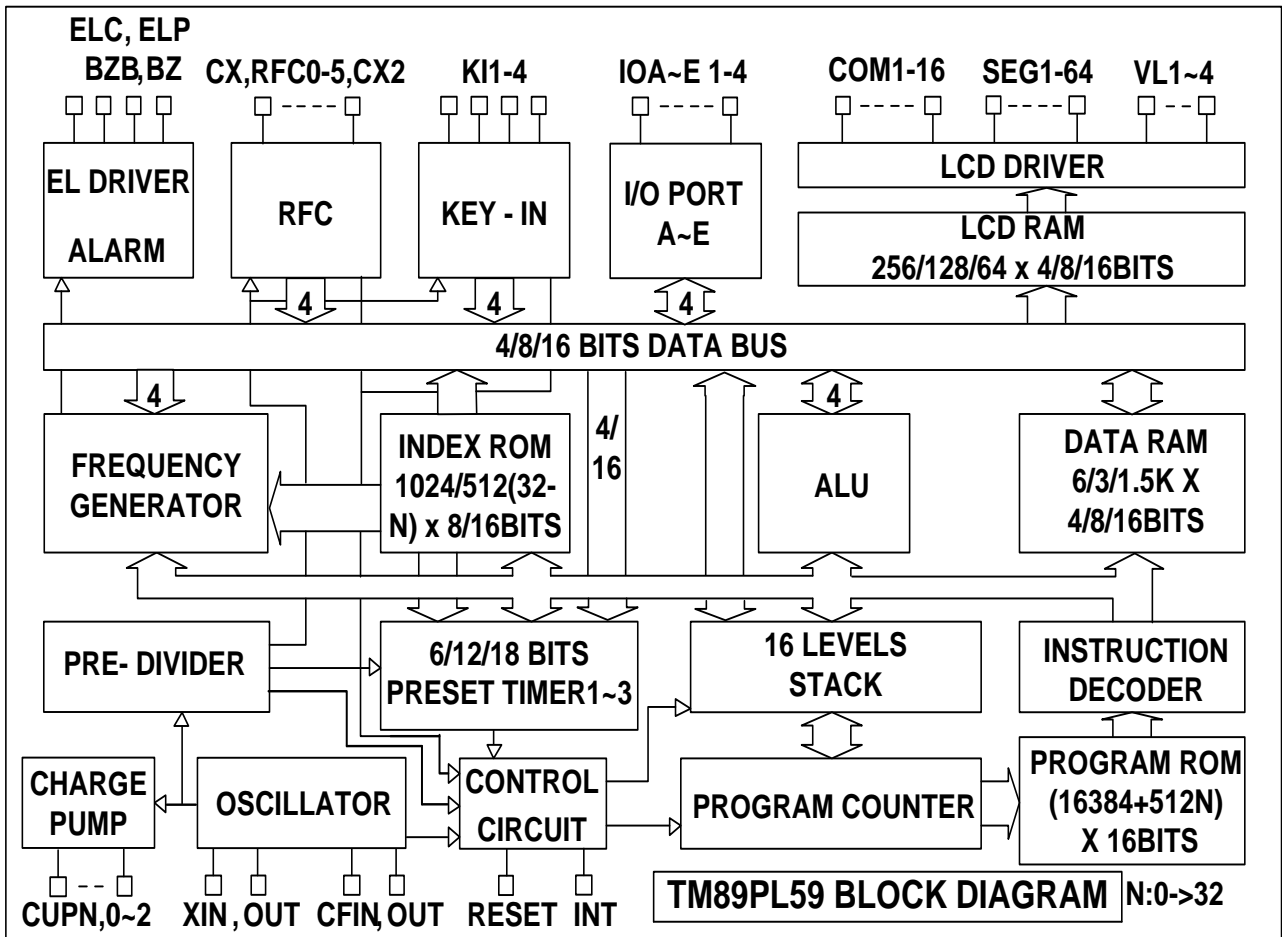

PAD ASSIGNMENT

No	Name	No	Name	No	Name	No	Name
1	GND	36	SEG1(KO1)	71	SEG36	106	IOE3
2	XIN	37	SEG2(KO2)	72	SEG37	107	IOE4
3	XOUT	38	SEG3(KO3)	73	SEG38	108	IOD1
4	CFIN	39	SEG4(KO4)	74	SEG39	109	IOD2
5	CFOUT	40	SEG5(KO5)	75	SEG40	110	IOD3
6	BAK	41	SEG6(KO6)	76	SEG41	111	IOD4
7	VL1	42	SEG7(KO7)	77	SEG42	112	IOC1
8	VBAT	43	SEG8(KO8)	78	SEG43	113	IOC2
9	VL2	44	SEG9(KO9)	79	SEG44	114	IOC3
10	VL3	45	SEG10(KO10)	80	SEG45	115	IOC4
11	VL4	46	SEG11(KO11)	81	SEG46	116	IOA1
12	CUPN	47	SEG12(KO12)	82	SEG47	117	IOA2
13	CUP0	48	SEG13(KO13)	83	SEG48	118	IOA3
14	CUP1	49	SEG14(KO14)	84	SEG49	119	IOA4
15	CUP2	50	SEG15(KO15)	85	SEG50	120	CX
16	IOB1/KI1	51	SEG16(KO16)	86	SEG51	121	RFC0
17	IOB2/KI2	52	SEG17	87	SEG52	122	RFC1
18	IOB3/KI3	53	SEG18	88	SEG53	123	RFC2
19	IOB4/KI4	54	SEG19	89	SEG54	124	RFC3
20	COM1	55	SEG20	90	SEG55	125	RFC4
21	COM2	56	SEG21	91	SEG56	126	RFC5
22	COM3	57	SEG22	92	SEG57	127	CX2
23	COM4	58	SEG23	93	SEG58	128	INT
24	COM5	59	SEG24	94	SEG59	129	RESETB
25	COM6	60	SEG25	95	SEG60		
26	COM7	61	SEG26	96	SEG61		
27	COM8	62	SEG27	97	SEG62		
28	COM9	63	SEG28	98	SEG63		
29	COM10	64	SEG29	99	SEG64		
30	COM11	65	SEG30	100	ELC		
31	COM12	66	SEG31	101	ELP		
32	COM13	67	SEG32	102	BZB		
33	COM14	68	SEG33	103	BZ		
34	COM15	69	SEG34	104	IOE1		
35	COM16	70	SEG35	105	IOE2		

PIN DESCRIPTION

Name	I/O	Description
BAK	P	Positive Back-up voltage. At 3V power mode, connect a 0.1u capacitor to GND. Positive voltage is needed to BAK for Serial Program/Read Mode.
VBAT	P	Positive supply voltage. Positive voltage is needed to VBAT for Serial Program/Read Mode.
VL1~4	P	LCD supply voltage. If “External LCD Regulator for 3V Power Mode” option = “VL1(EXTERNAL LCD REGULATOR FOR 3V POWER MODE)”, connect positive power or regulator output to VL1. If “External LCD Regulator for 3V Power Mode” option = “VL2(EXTERNAL LCD REGULATOR FOR 3V POWER MODE)”, connect positive power or regulator output to VL2. If “EXTERNAL LCD REGULATOR FOR 3V POWER MODE” option= “NO USE(VL1 /2=VBAT FOR 1.5/3V POWER MODE)”, VL1/2 build-in output voltage from VBAT by 1.5/3V POWER MODE. If “EXTERNAL LCD REGULATOR FOR 3V POWER MODE” option= “NO USE(VL1(BY VDL(0.95~1.70V)))” or “NO USE(VL2(BY VDL(1.80~2.55V)))”, connect Capacitors to VL1~4. High voltage is need to VL4 for Serial Program/Read Mode. Don't connect VL2~4 pins to VBAT pin in Serial Program/Read Mode.
RESETB	I	Input pin for external reset request signal, built-in internal pull-up resistor. Signal for Serial Program/Read Mode.
INT	I	Input pin for external INT request signal. . Falling edge or rising edge triggered is defined by option. . Internal pull-down or pull-up resistor is defined by option. Signal for Serial Program/Read Mode.
CUPN,0,1,2	O	Switching pins for supply the LCD driving voltage to the VL1~4 pins. . Connect the CUP1 to CUP2 pins with non-polarized electrolytic capacitors when chip operated in 1/3 bias mode. . Connect the CUP0 to CUP2 & CUP1 to CUP2 pins with non-polarized electrolytic capacitors when chip operated in 1/4 bias mode. . Connect the CUPN to CUP0 & CUP1 to CUP2 pins with non-polarized electrolytic capacitors when chip operated in more efficient 1/3 & 1/4 bias mode.
XIN XOUT	I O	Low speed oscillator, generates clock for time base functions (clock specified, LCD alternating frequency, Alarm signal frequency) or system clock oscillation. . The usage of 32 KHz Crystal oscillator or external RC oscillator is defined by option.
CFIN CFOUT	I O	High speed oscillator, system clock oscillation for FAST clock only or DUAL clock operation. . The usage of 3.58 MHz ceramic/resonator oscillator or external R type oscillator is defined by option
COM1~16	O	Output pins for driving the common pins of the LCD panel. COM1~16 can be defined as COMS or Open Drain type output by option.
SEG1-64	O	Output pins for driving the LCD panel segment.

Name	I/O	Description
IOA1-4	I/O	Input / Output port A.
IOB1-4	I/O	Input / Output port B, and can be defined as KI1~4 by code option.
IOC1-4	I/O	Input / Output port C.
IOD1~4	I/O	Input / Output port D.
IOE1~4	I/O	Input / Output port E.
CX,RFC0~5,CX2	I O	2 input pin and 6 output pins for RFC application.
ELC/ELP	O	Output port for EI panel drive.
BZB/BZ	O	Output port for alarm, clock or single tone melody generator.
KO1~KO16	O	Output port for key matrix scanning, shared with SEG1~16.
KI1~4	I	Input port for key matrix scanning, and can be defined as IOB1 ~ IOB4 by code option.
GND	P	Negative supply voltage. Negative voltage is need to GND for Serial Program/Read Mode

SERIAL PROGRAM/READ CONNECT PINS:

VBAT, BAK, VL4, GND, RESETB, CX, RFC0

RAM & INITIAL PAGE ASSIGNMENT

Mode	Initial Page	Page Number	Instruction inserted for set other Page by Compiler
Rx (0000~17FFh) (0100~017Fh for LCD)	0000~007Fh(0)	48 (x128)	SRX X (X : 1~2Fh ; X : 2,3h for LCD)
Ry (0000~17FFh) (0100~017Fh for LCD)	0070~007Fh(7)	384 (x16)	SRY X (X : 0~6,8~17Fh ; X : 10~1Fh for LCD)
Lz (000~7Fh)	0~1Fh(0)	4(x32)	SLZ X (X : 0~3h)

6K x 4 bits RAM

\$0000	Rx Page 0h (Initial Page)
\$007F	Ry Page 0~(7)h
\$0080	MHL/RHL 16 Address
\$00BF	-----
\$00C0	MZR/RZR 16 Address
\$00FF	-----
\$0100	Rx Page 2h (LCD)
\$017F	Ry Page 10~17h
\$0180	Rx Page 3h (LCD)
\$01FF	Ry Page 18~1Fh
\$0200	STACK 16 Level
\$023F	-----
\$0240	-----
\$027F	-----
\$1780	Rx Page 2Fh
\$17FF	Ry Page 178~17Fh

\$0,0000,10XX,XX00b <= IDBF3~0
 \$0,0000,10XX,XX01b <= IDBF7~4
 \$0,0000,10XX,XX10b <= IDBF11~8
 \$0,0000,10XX,XX11b <= IDBF15~12

\$0,0000,11XX,XX00b <= ZRBF3~0
 \$0,0000,11XX,XX01b <= ZRBF7~4
 \$0,0000,11XX,XX10b <= ZRBF11~8
 \$0,0000,11XX,XX11b <= ZRBF15~12

128 x 8 bits LCD

\$00(\$0101,0100)	Lz Page 0h (Initial Page)
\$1F(\$013F,013E)	-----
\$20(\$0141,0140)	Lz Page 1h
\$3F(\$017E,017E)	-----
\$40(\$0181,0180)	Lz Page 2h
\$5F(\$01BF,01BE)	-----
\$60(\$01C1,01C0)	Lz Page 3h
\$7F(\$01FF,01FE)	-----

16 level x 16 bits STACK

level	PC15~12	PC11~8	PC7~4	PC3~0
1	\$0203	\$0202	\$0201	\$0200
2	\$0207	\$0206	\$0205	\$0204
3	\$020B	\$020A	\$0209	\$0208
4	\$020F	\$020E	\$020D	\$020C
5	\$0213	\$0212	\$0211	\$0210
6	\$0217	\$0216	\$0215	\$0214
7	\$021B	\$021A	\$0219	\$0218
8	\$021F	\$021E	\$021D	\$021C
9	\$0223	\$0222	\$0221	\$0220
10	\$0227	\$0226	\$0225	\$0224
11	\$022B	\$022A	\$0229	\$0228
12	\$022F	\$022E	\$022D	\$022C
13	\$0233	\$0232	\$0231	\$0230
14	\$0237	\$0236	\$0235	\$0234
15	\$023B	\$023A	\$0239	\$0238
16	\$023F	\$023E	\$023D	\$023C

Configuration of LCD RAM Area

ADDRESS		BIT3	BIT2	BIT1	BIT0	ADDRESS		BIT3	BIT2	BIT1	BIT0
		COM4	COM3	COM2	COM1			COM8	COM7	COM6	COM5
Rx(even)	Lz	DBUSD	DBUSC	DBUSB	DBUSA	Rx(even)	Lz	DBUSD	DBUSC	DBUSB	DBUSA
Rx(odd)		DBUSH	DBUSG	DBUSF	DBUSE	Rx(odd)		DBUSH	DBUSG	DBUSF	DBUSE
0100H	00	SEG1	SEG1	SEG1	SEG1	0140H	20	SEG1	SEG1	SEG1	SEG1
0101H		SEG2	SEG2	SEG2	SEG2	0141H		SEG2	SEG2	SEG2	SEG2
0102H	01	SEG3	SEG3	SEG3	SEG3	0142H	21	SEG3	SEG3	SEG3	SEG3
0103H		SEG4	SEG4	SEG4	SEG4	0143H		SEG4	SEG4	SEG4	SEG4
0104H	02	SEG5	SEG5	SEG5	SEG5	0144H	22	SEG5	SEG5	SEG5	SEG5
0105H		SEG6	SEG6	SEG6	SEG6	0145H		SEG6	SEG6	SEG6	SEG6
0106H	03	SEG7	SEG7	SEG7	SEG7	0146H	23	SEG7	SEG7	SEG7	SEG7
0107H		SEG8	SEG8	SEG8	SEG8	0147H		SEG8	SEG8	SEG8	SEG8
0108H	04	SEG9	SEG9	SEG9	SEG9	0148H	24	SEG9	SEG9	SEG9	SEG9
0109H		SEG10	SEG10	SEG10	SEG10	0149H		SEG10	SEG10	SEG10	SEG10
010AH	05	SEG11	SEG11	SEG11	SEG11	014AH	25	SEG11	SEG11	SEG11	SEG11
010BH		SEG12	SEG12	SEG12	SEG12	014BH		SEG12	SEG12	SEG12	SEG12
010CH	06	SEG13	SEG13	SEG13	SEG13	014CH	26	SEG13	SEG13	SEG13	SEG13
010DH		SEG14	SEG14	SEG14	SEG14	014DH		SEG14	SEG14	SEG14	SEG14
010EH	07	SEG15	SEG15	SEG15	SEG15	014EH	27	SEG15	SEG15	SEG15	SEG15
010FH		SEG16	SEG16	SEG16	SEG16	014FH		SEG16	SEG16	SEG16	SEG16
0110H	08	SEG17	SEG17	SEG17	SEG17	0150H	28	SEG17	SEG17	SEG17	SEG17
0111H		SEG18	SEG18	SEG18	SEG18	0151H		SEG18	SEG18	SEG18	SEG18
0112H	09	SEG19	SEG19	SEG19	SEG19	0152H	29	SEG19	SEG19	SEG19	SEG19
0113H		SEG20	SEG20	SEG20	SEG20	0153H		SEG20	SEG20	SEG20	SEG20
0114H	0A	SEG21	SEG21	SEG21	SEG21	0154H	2A	SEG21	SEG21	SEG21	SEG21
0115H		SEG22	SEG22	SEG22	SEG22	0155H		SEG22	SEG22	SEG22	SEG22
0116H	0B	SEG23	SEG23	SEG23	SEG23	0156H	2B	SEG23	SEG23	SEG23	SEG23
0117H		SEG24	SEG24	SEG24	SEG24	0157H		SEG24	SEG24	SEG24	SEG24
0118H	0C	SEG25	SEG25	SEG25	SEG25	0158H	2C	SEG25	SEG25	SEG25	SEG25
0119H		SEG26	SEG26	SEG26	SEG26	0159H		SEG26	SEG26	SEG26	SEG26
011AH	0D	SEG27	SEG27	SEG27	SEG27	015AH	2D	SEG27	SEG27	SEG27	SEG27
011BH		SEG28	SEG28	SEG28	SEG28	015BH		SEG28	SEG28	SEG28	SEG28
011CH	0E	SEG29	SEG29	SEG29	SEG29	015CH	2E	SEG29	SEG29	SEG29	SEG29
011DH		SEG30	SEG30	SEG30	SEG30	015DH		SEG30	SEG30	SEG30	SEG30
011EH	0F	SEG31	SEG31	SEG31	SEG31	015EH	2F	SEG31	SEG31	SEG31	SEG31
011FH		SEG32	SEG32	SEG32	SEG32	015FH		SEG32	SEG32	SEG32	SEG32
0120H	10	SEG33	SEG33	SEG33	SEG33	0160H	30	SEG33	SEG33	SEG33	SEG33
0121H		SEG34	SEG34	SEG34	SEG34	0161H		SEG34	SEG34	SEG34	SEG34
0122H	11	SEG35	SEG35	SEG35	SEG35	0162H	31	SEG35	SEG35	SEG35	SEG35
0123H		SEG36	SEG36	SEG36	SEG36	0163H		SEG36	SEG36	SEG36	SEG36
0124H	12	SEG37	SEG37	SEG37	SEG37	0164H	32	SEG37	SEG37	SEG37	SEG37
0125H		SEG38	SEG38	SEG38	SEG38	0165H		SEG38	SEG38	SEG38	SEG38
0126H	13	SEG39	SEG39	SEG39	SEG39	0166H	33	SEG39	SEG39	SEG39	SEG39
0127H		SEG40	SEG40	SEG40	SEG40	0167H		SEG40	SEG40	SEG40	SEG40
0128H	14	SEG41	SEG41	SEG41	SEG41	0168H	34	SEG41	SEG41	SEG41	SEG41
0129H		SEG42	SEG42	SEG42	SEG42	0169H		SEG42	SEG42	SEG42	SEG42
012AH	15	SEG43	SEG43	SEG43	SEG43	016AH	35	SEG43	SEG43	SEG43	SEG43
012BH		SEG44	SEG44	SEG44	SEG44	016BH		SEG44	SEG44	SEG44	SEG44
012CH	16	SEG45	SEG45	SEG45	SEG45	016CH	36	SEG45	SEG45	SEG45	SEG45
012DH		SEG46	SEG46	SEG46	SEG46	016DH		SEG46	SEG46	SEG46	SEG46
012EH	17	SEG47	SEG47	SEG47	SEG47	016EH	37	SEG47	SEG47	SEG47	SEG47

ADDRESS		BIT3	BIT2	BIT1	BIT0	ADDRESS		BIT3	BIT2	BIT1	BIT0
		COM4	COM3	COM2	COM1			COM8	COM7	COM6	COM5
Rx(even)	Lz	DBUSD	DBUSC	DBUSB	DBUSA	Rx(even)	Lz	DBUSD	DBUSC	DBUSB	DBUSA
Rx(odd)		DBUSH	DBUSG	DBUSF	DBUSE	Rx(odd)		DBUSH	DBUSG	DBUSF	DBUSE
012FH	18	SEG48	SEG48	SEG48	SEG48	016FH	38	SEG48	SEG48	SEG48	SEG48
0130H		SEG49	SEG49	SEG49	SEG49	0170H		SEG49	SEG49	SEG49	SEG49
0131H		SEG50	SEG50	SEG50	SEG50	0171H		SEG50	SEG50	SEG50	SEG50
0132H	19	SEG51	SEG51	SEG51	SEG51	0172H	39	SEG51	SEG51	SEG51	SEG51
0133H		SEG52	SEG52	SEG52	SEG52	0173H		SEG52	SEG52	SEG52	SEG52
0134H	1A	SEG53	SEG53	SEG53	SEG53	0174H	3A	SEG53	SEG53	SEG53	SEG53
0135H		SEG54	SEG54	SEG54	SEG54	0175H		SEG54	SEG54	SEG54	SEG54
0136H	1B	SEG55	SEG55	SEG55	SEG55	0176H	3B	SEG55	SEG55	SEG55	SEG55
0137H		SEG56	SEG56	SEG56	SEG56	0177H		SEG56	SEG56	SEG56	SEG56
0138H	1C	SEG57	SEG57	SEG57	SEG57	0178H	3C	SEG57	SEG57	SEG57	SEG57
0139H		SEG58	SEG58	SEG58	SEG58	0179H		SEG58	SEG58	SEG58	SEG58
013AH	1D	SEG59	SEG59	SEG59	SEG59	017AH	3D	SEG59	SEG59	SEG59	SEG59
013BH		SEG60	SEG60	SEG60	SEG60	017BH		SEG60	SEG60	SEG60	SEG60
013CH	1E	SEG61	SEG61	SEG61	SEG61	017CH	3E	SEG61	SEG61	SEG61	SEG61
013DH		SEG62	SEG62	SEG62	SEG62	017DH		SEG62	SEG62	SEG62	SEG62
013EH	1F	SEG63	SEG63	SEG63	SEG63	017EH	3F	SEG63	SEG63	SEG63	SEG63
013FH		SEG64	SEG64	SEG64	SEG64	017FH		SEG64	SEG64	SEG64	SEG64
		C_DC4	C_DC3	C_DC2	C_OD4			C_OD3	C_OD8	C_OD7	C_OD6

ADDRESS		BIT3	BIT2	BIT1	BIT0	ADDRESS		BIT3	BIT2	BIT1	BIT0
		COM12	COM11	COM10	COM9			COM16	COM15	COM14	COM13
Rx(even)	Lz	DBUSD	DBUSC	DBUSB	DBUSA	Rx(even)	Lz	DBUSD	DBUSC	DBUSB	DBUSA
Rx(odd)		DBUSH	DBUSG	DBUSF	DBUSE	Rx(odd)		DBUSH	DBUSG	DBUSF	DBUSE
0180H	40	SEG1	SEG1	SEG1	SEG1	01C0H	60	SEG1	SEG1	SEG1	SEG1
0181H		SEG2	SEG2	SEG2	SEG2	01C1H		SEG2	SEG2	SEG2	SEG2
0182H	41	SEG3	SEG3	SEG3	SEG3	01C2H	61	SEG3	SEG3	SEG3	SEG3
0183H		SEG4	SEG4	SEG4	SEG4	01C3H		SEG4	SEG4	SEG4	SEG4
0184H	42	SEG5	SEG5	SEG5	SEG5	01C4H	62	SEG5	SEG5	SEG5	SEG5
0185H		SEG6	SEG6	SEG6	SEG6	01C5H		SEG6	SEG6	SEG6	SEG6
0186H	43	SEG7	SEG7	SEG7	SEG7	01C6H	63	SEG7	SEG7	SEG7	SEG7
0187H		SEG8	SEG8	SEG8	SEG8	01C7H		SEG8	SEG8	SEG8	SEG8
0188H	44	SEG9	SEG9	SEG9	SEG9	01C8H	64	SEG9	SEG9	SEG9	SEG9
0189H		SEG10	SEG10	SEG10	SEG10	01C9H		SEG10	SEG10	SEG10	SEG10
018AH	45	SEG11	SEG11	SEG11	SEG11	01CAH	65	SEG11	SEG11	SEG11	SEG11
018BH		SEG12	SEG12	SEG12	SEG12	01CBH		SEG12	SEG12	SEG12	SEG12
018CH	46	SEG13	SEG13	SEG13	SEG13	01CCH	66	SEG13	SEG13	SEG13	SEG13
018DH		SEG14	SEG14	SEG14	SEG14	01CDH		SEG14	SEG14	SEG14	SEG14
018EH	47	SEG15	SEG15	SEG15	SEG15	01CEH	67	SEG15	SEG15	SEG15	SEG15
018FH		SEG16	SEG16	SEG16	SEG16	01CFH		SEG16	SEG16	SEG16	SEG16
0190H	48	SEG17	SEG17	SEG17	SEG17	01D0H	68	SEG17	SEG17	SEG17	SEG17
0191H		SEG18	SEG18	SEG18	SEG18	01D1H		SEG18	SEG18	SEG18	SEG18
0192H	49	SEG19	SEG19	SEG19	SEG19	01D2H	69	SEG19	SEG19	SEG19	SEG19
0193H		SEG20	SEG20	SEG20	SEG20	01D3H		SEG20	SEG20	SEG20	SEG20
0194H	4A	SEG21	SEG21	SEG21	SEG21	01D4H	6A	SEG21	SEG21	SEG21	SEG21
0195H		SEG22	SEG22	SEG22	SEG22	01D5H		SEG22	SEG22	SEG22	SEG22
0196H	4B	SEG23	SEG23	SEG23	SEG23	01D6H	6B	SEG23	SEG23	SEG23	SEG23
0197H		SEG24	SEG24	SEG24	SEG24	01D7H		SEG24	SEG24	SEG24	SEG24
0198H	4C	SEG25	SEG25	SEG25	SEG25	01D8H	6C	SEG25	SEG25	SEG25	SEG25

ADDRESS		BIT3	BIT2	BIT1	BIT0	ADDRESS		BIT3	BIT2	BIT1	BIT0
		COM12	COM11	COM10	COM9			COM16	COM15	COM14	COM13
Rx(even)	Lz	DBUSD	DBUSC	DBUSB	DBUSA	Rx(even)	Lz	DBUSD	DBUSC	DBUSB	DBUSA
Rx(odd)		DBUSH	DBUSG	DBUSF	DBUSE	Rx(odd)		DBUSH	DBUSG	DBUSF	DBUSE
0199H	4D	SEG26	SEG26	SEG26	SEG26	01D9H	6D	SEG26	SEG26	SEG26	SEG26
019AH		SEG27	SEG27	SEG27	SEG27	01DAH		SEG27	SEG27	SEG27	SEG27
019BH		SEG28	SEG28	SEG28	SEG28	01DBH		SEG28	SEG28	SEG28	SEG28
019CH	4E	SEG29	SEG29	SEG29	SEG29	01DCH	6E	SEG29	SEG29	SEG29	SEG29
019DH		SEG30	SEG30	SEG30	SEG30	01DDH		SEG30	SEG30	SEG30	SEG30
019EH	4F	SEG31	SEG31	SEG31	SEG31	01DEH	6F	SEG31	SEG31	SEG31	SEG31
019FH		SEG32	SEG32	SEG32	SEG32	01DFH		SEG32	SEG32	SEG32	SEG32
01A0H	50	SEG33	SEG33	SEG33	SEG33	01E0H	70	SEG33	SEG33	SEG33	SEG33
01A1H		SEG34	SEG34	SEG34	SEG34	01E1H		SEG34	SEG34	SEG34	SEG34
01A2H	51	SEG35	SEG35	SEG35	SEG35	01E2H	71	SEG35	SEG35	SEG35	SEG35
01A3H		SEG36	SEG36	SEG36	SEG36	01E3H		SEG36	SEG36	SEG36	SEG36
01A4H	52	SEG37	SEG37	SEG37	SEG37	01E4H	72	SEG37	SEG37	SEG37	SEG37
01A5H		SEG38	SEG38	SEG38	SEG38	01E5H		SEG38	SEG38	SEG38	SEG38
01A6H	53	SEG39	SEG39	SEG39	SEG39	01E6H	73	SEG39	SEG39	SEG39	SEG39
01A7H		SEG40	SEG40	SEG40	SEG40	01E7H		SEG40	SEG40	SEG40	SEG40
01A8H	54	SEG41	SEG41	SEG41	SEG41	01E8H	74	SEG41	SEG41	SEG41	SEG41
01A9H		SEG42	SEG42	SEG42	SEG42	01E9H		SEG42	SEG42	SEG42	SEG42
01AAH	55	SEG43	SEG43	SEG43	SEG43	01EAH	75	SEG43	SEG43	SEG43	SEG43
01ABH		SEG44	SEG44	SEG44	SEG44	01EBH		SEG44	SEG44	SEG44	SEG44
01ACH	56	SEG45	SEG45	SEG45	SEG45	01ECH	76	SEG45	SEG45	SEG45	SEG45
01ADH		SEG46	SEG46	SEG46	SEG46	01EDH		SEG46	SEG46	SEG46	SEG46
01AEH	57	SEG47	SEG47	SEG47	SEG47	01EEH	77	SEG47	SEG47	SEG47	SEG47
01AFH		SEG48	SEG48	SEG48	SEG48	01EFH		SEG48	SEG48	SEG48	SEG48
01B0H	58	SEG49	SEG49	SEG49	SEG49	01F0H	78	SEG49	SEG49	SEG49	SEG49
01B1H		SEG50	SEG50	SEG50	SEG50	01F1H		SEG50	SEG50	SEG50	SEG50
01B2H	59	SEG51	SEG51	SEG51	SEG51	01F2H	79	SEG51	SEG51	SEG51	SEG51
01B3H		SEG52	SEG52	SEG52	SEG52	01F3H		SEG52	SEG52	SEG52	SEG52
01B4H	5A	SEG53	SEG53	SEG53	SEG53	01F4H	7A	SEG53	SEG53	SEG53	SEG53
01B5H		SEG54	SEG54	SEG54	SEG54	01F5H		SEG54	SEG54	SEG54	SEG54
01B6H	5B	SEG55	SEG55	SEG55	SEG55	01F6H	7B	SEG55	SEG55	SEG55	SEG55
01B7H		SEG56	SEG56	SEG56	SEG56	01F7H		SEG56	SEG56	SEG56	SEG56
01B8H	5C	SEG57	SEG57	SEG57	SEG57	01F8H	7C	SEG57	SEG57	SEG57	SEG57
01B9H		SEG58	SEG58	SEG58	SEG58	01F9H		SEG58	SEG58	SEG58	SEG58
01BAH	5D	SEG59	SEG59	SEG59	SEG59	01FAH	7D	SEG59	SEG59	SEG59	SEG59
01BBH		SEG60	SEG60	SEG60	SEG60	01FBH		SEG60	SEG60	SEG60	SEG60
01BCH	5E	SEG61	SEG61	SEG61	SEG61	01FCH	7E	SEG61	SEG61	SEG61	SEG61
01BDH		SEG62	SEG62	SEG62	SEG62	01FDH		SEG62	SEG62	SEG62	SEG62
01BEH	5F	SEG63	SEG63	SEG63	SEG63	01FEH	7F	SEG63	SEG63	SEG63	SEG63
01BFH		SEG64	SEG64	SEG64	SEG64	01FFH		SEG64	SEG64	SEG64	SEG64
		C_DC12	C_DC11	C_DC10	C_DC9			C_DC16	C_DC15	CDC14	C_DC13
		C_OD12	C_OD11	C_OD10	C_OD9			C_OD16	C_OD15	COD14	C_OD13

ABSOLUTE MAXIMUM RATINGS

GND= 0V

Name	Symbol	Range	Unit
Maximum Supply Voltage	VBAT	-0.3 to 3.6	V
	VL1	-0.3 to 2.1	V
	VL2	-0.3 to 3.6	V
	VL3	-0.3 to 6.0	V
	VL4	-0.3 to 6.0	V
Maximum Input Voltage	Vin1	-0.3 to VBAT+0.3	V
	Vin2	-0.3 to VL1/2+0.3	V
Maximum output Voltage	Vout1	-0.3 to VBAT+0.3	
	Vout2	-0.3 to VL1/2+0.3	V
	Vout3	-0.3 to VL3+0.3	V
	Vout4	-0.3 to VL4+0.3	V
Maximum Operating Temperature	Topg	-40 to +80	°C
Maximum Storage Temperature	Tstg	-40 to +125	°C

POWER CONSUMPTION

At Ta = -40°C to 80°C, GND = 0V

Halt Conduction: BCF=0, 1/3Bias, 1/16Duty, LCD Alternating Frequency = PH5,

Charge Pump Cycle = PH4,

Only operates in 32.768 KHz Crystal Oscillator, without loading.

Name	Sym.	Power Mode	Min.	Typ.	Max.	Unit
	IHALT1	1.5V Mode, VBAT = 1.5V		5		uA
HALT mode	IHALT2	3V Mode(BCF=0=>BAK=VL1), VBAT = 3.0V		2		uA
	IHALT2	3V Mode(BCF=0=>BAK=VBAT), VBAT = 3.0V		10		uA
STOP mode	ISTOP				1	uA

Note: When RC oscillator function is operating, the current consumption will depend on the frequency of oscillation.

ALLOWABLE OPERATING CONDITIONS

at#1:1.5V Power Mode

at#2: 3V Power Mode

at Ta=-40°C to 80°C,GND= 0V; X'tal No Matched Capacitance

Name	Symb.	Condition	Min.	Max.	Unit
Supply Voltage	VBAT		1.2	3.6	
	VL1		0.95	1.8	V
	VL2		2.0	3.6	V
	VL3		3.0	6.0	V
	VL4		3.0	6.0	V
Oscillator Start-Up Voltage	VDDB	Crystal Mode BCF = 1 #1	1.2		V
		Crystal Mode BCF = 1 #2	1.8		V
Oscillator Sustain Voltage	VDDB	Crystal Mode BCF = 0		1.1	V
Supply Voltage	VBAT	1.5V Power Mode	1.2	1.8	V
Supply Voltage	VBAT	3V Power Mode BAK=VBAT for BCF=0	2.2	3.6	V
		3V Power Mode BAK=VL1 for BCF=0	2.4	3.6	V
Input "H" Voltage	Vih1	I/O,DC	VBAT-0.6	VBAT+0.6	V
Input "L" Voltage	Vil1		-0.6	0.6	V
Input "H" Voltage	Vih2	CX/2	VL2-0.6	VL2+0.6	V
Input "L" Voltage	Vil2		-0.6	0.6	V
Input "H" Voltage	Vih3	OSCIN	0.8xBAK	BAK	V
Input "L" Voltage	Vil3		0	0.2xBAK	V
Operating Freq	Fopg1	Crystal Mode	32		KHz
	Fopg2	RC Mode	10	4096	KHz
	Fopg3	CF Mode	1000	4096	KHz

ALLOWABLE OPERATING FREQUENCY

At Ta = -40°C to 80°C, GND = 0V

Condition	Max. Operating Frequency
BAK = 1.2V	1M Hz
BAK = 1.8V	4M Hz
BAK = 2.2V	6M Hz

INTERNAL RC FREQUENCY RANGE

At Ta = -40°C to 80°C, GND = 0V

Option Mode	BAK	Min.	Typ.	Max.
250 KHz	1.5V	100 KHz	200 KHz	300 KHz
	3.0V	200 KHz	250 KHz	300 KHz
500 KHz	1.5V	200 KHz	400 KHz	600 KHz
	3.0V	400 KHz	500 KHz	600 KHz

ELECTRICAL CHARACTERISTICS**Input Resistance**

At #1: VBAT = 1.5V (1.5V Power Mode)

At #2: VBAT = 3.0V (3V Power Mode)

At Ta = -40°C to 80°C, GND = 0V

Name	Symb.	Condition	Min.	Typ.	Max.	Unit
“L” Level Hold Tr (IOC)	Rllh1	Vi=0.2VBAT, #1	10	40	100	Kohm
	Rllh2	Vi=0.2VBAT, #2	10	40	100	Kohm
IOC Pull-Down Tr	Rmad1	Vi=VBAT, #1	200	500	1000	Kohm
	Rmad2	Vi=VBAT, #2	200	500	1000	Kohm
INT Pull-up Tr	Rintu1	Vi=VBAT, #1	50	200	1000	Kohm
	Rintu2	Vi=VBAT, #2	50	350	1000	Kohm
INT Pull-Down Tr	Rintd1	Vi=GND, #1	200	500	1000	Kohm
	Rintd2	Vi=GND, #2	200	500	1000	Kohm
RES Pull-Up R	Rres1	Vi=GND or VBAT, #1	10	40	100	Kohm
	Rres2	Vi=GND or VBAT, #2	10	40	100	Kohm

DC Output Characteristics

At #1: VBAT = 1.2V

At #2: VBAT = 2.4V

At Ta = -40°C to 80°C, GND = 0V

Name	Symb.	Condition	Port	Min.	Typ.	Max.	Unit
Output "H" Voltage	Voh1a	Ioh=-100 uA, #1	COM5 ~ 16 IOB ~ E ELC, ELP BZB, BZ	1.0			V
	Voh2a	Ioh=-1 mA, #2		2.0			V
Output "L" Voltage	Vol1a	Iol=200 uA, #1				0.2	V
	Vol2a	Iol=2 mA, #2				0.4	V
Output "H" Voltage	Voh1b	Ioh=-200 uA, #1	IOA, RFC0 ~ 5, INT/CX/CX2 (Vol only)	1.0			V
	Voh2b	Ioh=-3 mA, #2		2.0			V
Output "L" Voltage	Vol1b	Iol=400 uA, #1				0.2	V
	Vol2b	Iol=5 mA, #2				0.4	V

Segment Driver Output Characteristics

At #1: VL1 = 1.2V

At #2: VL2 = 2.4V

At #3: VL1 = 1.05V

At #4: VL2 = 2.10V

Name	Symb.	Condition	For	Min.	Typ.	Max.	Unit.	
1/3 Bias display Mode								
Output "H" Voltage	Voh12h	Ioh=-1 uA, #1, #2	SEG-n	3.4			V	
	Voh34h	Ioh=-1 uA, #3, #4		2.95			V	
Output "M1" Voltage	Vom112h	Iol/h=+/-1 uA, #1, #2		1.0		1.4	V	
	Vom134h	Iol/h=+/-1 uA, #3, #4		0.85		1.25	V	
Output "M2" Voltage	Vom212h	Iol/h=+/-1 uA, #1, #2		2.2		2.6	V	
	Vom234h	Iol/h=+/-1 uA, #3, #4		1.95		2.30	V	
Output "L" Voltage	Vol12h	Iol=1 uA, #1, #2				0.2	V	
	Vol34h	Iol=1 uA, #3, #4				0.2	V	
Output "H" Voltage	Voh12i	Ioh=-10 uA, #1, #2		COM-n	3.4			V
	Voh34i	Ioh=-10 uA, #3, #4			2.95			V
Output "M1" Voltage	Vom112i	Iol/h=+/-10 uA, #1, #2	1.0			1.4	V	
	Vom134i	Iol/h=+/-10 uA, #3, #4	0.85			1.25	V	
Output "M2" Voltage	Vom212i	Iol/h=+/-10 uA, #1, #2	2.2			2.6	V	
	Vom234i	Iol/h=+/-10 uA, #3, #4	1.90			2.30	V	
Output "L" Voltage	Vol12i	Iol=10 uA, #1, #2				0.2	V	
	Vol34i	Iol=10 uA, #3, #4				0.2	V	
1/4 Bias display Mode								
Output "H" Voltage	Voh12j	Ioh=-1 uA, #1, #2	SEG-n		4.6			V
	Voh34j	Ioh=-1 uA, #3, #4		4.00				
Output "M2" Voltage	Vom212j	Iol/h=+/-1 uA, #1, #2		2.2		2.6	V	

Name	Symb.	Condition	For	Min.	Typ.	Max.	Unit.
Output "L" Voltage	Vom234j	lol/h=+/-1 uA, #3, #4		1.90		2.30	V
	Vol12j	lol=1 uA, #1, #2				0.2	V
	Vol12j	lol=1 uA, #3, #4				0.2	V
Output "H" Voltage	Voh12k	loh=-10 uA, #1, #2	COM-n	4.6			V
	Voh34k	loh=-10 uA, #3, #4		4.00			V
Output "M1" Voltage	Vom112k	lol/h=+/-10 uA, #1, #2		1.0		1.4	V
	Vom134k	lol/h=+/-10 uA, #3, #4		0.85		1.25	V
Output "M3" Voltage	Vom312k	lol/h=+/-10 uA, #1, #2		3.4		3.8	V
	Vom334k	lol/h=+/-10 uA, #3, #4		2.95		3.35	V
Output "L" Voltage	Vol12k	lol=10 uA, #1, #2				0.2	V
	Vol34k	lol=10 uA, #3, #4				0.2	V

Regulator & Low-Battery-Detect Circuit Characteristics

at Ta= -20°C to 70°C, GND= 0V

Name	Symb.	Condition	Min.	Typ.	Max.	Unit
VREG regulator output for BAK	VREG	VDX3~0=F	Typ. -4%	1.95	Typ. +4%	V
		VDX3~0=E		1.90		
		VDX3~0=D		1.85		
		VDX3~0=C		1.80		
		VDX3~0=B		1.75		
		VDX3~0=A		1.70		
		VDX3~0=9		1.65		
		VDX3~0=8		1.60		
		VDX3~0=7		1.55		
		VDX3~0=6		1.50		
		VDX3~0=5		1.45		
		VDX3~0=4		1.40		
		VDX3~0=3		1.35		
		VDX3~0=2		1.30		
VDX3~0=1	1.25					
VDX3~0=0	1.20					
VDL regulator output for VL2 orBAK & for 3V Power Mode only & initial=2.10V	VDL	VDL3~0=F	Typ. -4%	2.55	Typ. +4%	V
		VDL3~0=E		2.50		
		VDL3~0=D		2.45		
		VDL3~0=C		2.40		
		VDL3~0=B		2.35		
		VDL3~0=A		2.30		
		VDL3~0=9		2.25		
		VDL3~0=8		2.20		
		VDL3~0=7		2.15		
		VDL3~0=6		2.10		
		VDL3~0=5		2.05		
		VDL3~0=4		2.00		
		VDL3~0=3		1.95		
		VDL3~0=2		1.90		
VDL3~0=1	1.85					
VDL3~0=0	1.80					
VDL regulator output for VL1 & initial=1.05V	VDL	VDL3~0=F	Typ. -4%	1.70	Typ. +4%	V
		VDL3~0=E		1.65		
		VDL3~0=D		1.60		
		VDL3~0=C		1.55		
VDL3~0=B	1.50					

Name	Symb.	Condition	Min.	Typ.	Max.	Unit
		VDL3~0=A		1.45		
		VDL3~0=9		1.40		
		VDL3~0=8		1.35		
		VDL3~0=7		1.30		
		VDL3~0=6		1.25		
		VDL3~0=5		1.20		
		VDL3~0=4		1.15		
		VDL3~0=3		1.10		
		VDL3~0=2		1.05		
		VDL3~0=1		1.00		
		VDL3~0=0		0.95		

Name	Symb.	Condition	Min.	Typ.	Max.	Unit			
VREG Stable time, BAK with 0.1 uF Capacitor	TREG				600	mS			
LBD voltage	VLBD	LBD4~0=1F	Typ. -5%	2.90	Typ. +5%	V			
		LBD4~0=1E		2.85					
		LBD4~0=1D		2.80					
		LBD4~0=1C		2.75					
		LBD4~0=1B		2.70					
		LBD4~0=1A		2.65					
		LBD4~0=19		2.60					
		LBD4~0=18		2.55					
		LBD4~0=17		2.50					
		LBD4~0=16		2.45					
		LBD4~0=15		2.40					
		LBD4~0=14		2.35					
		LBD4~0=13		2.30					
		LBD4~0=12		2.25					
		LBD4~0=11		2.20					
		LBD4~0=10	2.15						
		LBD4~0=0F	2.10						
		LBD4~0=0E	2.05						
		LBD4~0=0D	2.00						
		LBD4~0=0C	Typ. -0.1	1.95	Typ. +0.1	V			
		LBD4~0=0B		1.90					
		LBD4~0=0A		1.85					
		LBD4~0=09		1.80					
		LBD4~0=08		1.75					
		LBD4~0=07		1.70					
		LBD4~0=06		1.65					
		LBD4~0=05		1.60					
		LBD4~0=04		1.55					
		LBD4~0=03		1.50					
		LBD4~0=02		1.45					
LBD4~0=01	1.40								
LBD4~0=00	1.35								
LBD circuit response time	TLBD							100	uS
LVR2 circuit response time	TLVR2							1	mS

Note1: VREG & VDL : at VBAT=3.0/1.5V & voltage of option < VBAT for TM89PL59H/L

Low-Voltage-Reset Circuit Characteristics

at Ta= -40/20°C to 80/70°C, GND=0V for LVR1/2

Name	Symb.	Condition	Min.	Typ.	Max.	Unit
LVR1 Reset Voltage	Vlvr1	3V Power Mode Only	1.20	1.80	2.40	V
LVR2 Reset Voltage	Vlvr2	Code option	Typ. -5%	2.90	Typ. +5%	V
				2.85		
2.80						
2.75						
2.70						
2.65						
2.60						
2.55						
2.50						
2.45						
2.40						
2.35						
2.30						
2.25						
2.20						
2.15	Typ. -0.1	Typ. +0.1	V			
2.10						
2.05						
2.00						
1.95						
1.90						
1.85						
1.80						
1.75						
1.70						
1.65						
1.60						
1.55						
1.50						
1.45						
1.40 *1						
1.35 *1						

*1 : Ta= 0°C to 70°C, GND= 0V

TYPICAL APPLICATION CIRCUIT

This application circuit is only an example, and can not be guaranteed to work.

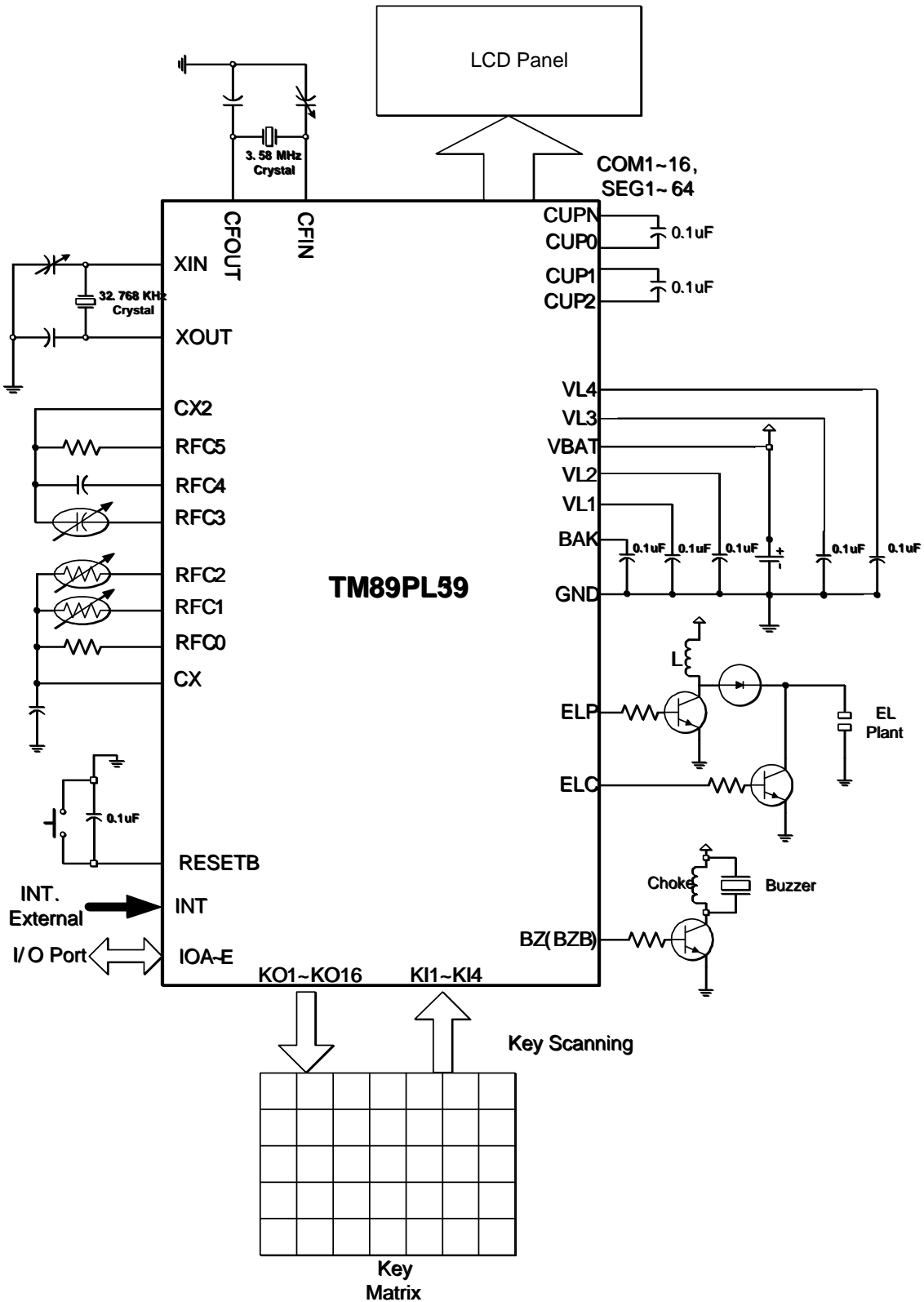

3V power mode , 1/4Bias , 1/16 Duty

ORDERING INFORMATION

The ordering information:

Ordering number	Package
TM89PL59-000	Wafer / Dice blank chip
TM89PL59-COD	Wafer / Dice with code

Appendix A: TM89PL59 Instruction Table

Instruction	Machine Code	Function	Flag/Remark
NOP	0000 0000 0000 0000	No Operation	
IDC& IDC% IDC\$	0000 0001 010B B010	'&,\$': HL ←HL+1 '%,\$': ZR ←ZR+1	'&': B4,3=01 '%': B4,3=10 '\$': B4,3=11
IDC8& IDC8% IDC8\$	0000 0001 010B B100	'&,\$': HL ←HL+2 '%,\$': ZR ←ZR+2	'&': B4,3=01 '%': B4,3=10 '\$': B4,3=11
IDCH& IDCH% IDCH\$	0000 0001 010B B110	'&,\$': HL ←HL+4 '%,\$': ZR ←ZR+4	'&': B4,3=01 '%': B4,3=10 '\$': B4,3=11
LID LID& LID% LID\$	@ZR,@HL 0000 0001 011B B010	(@ZR) '&,\$': HL ←HL+1 '%,\$': ZR ←ZR+1	' ': B4,3=00 '&': B4,3=01 '%': B4,3=10 '\$': B4,3=11
LID LID& LID% LID\$	@HL,@ZR 0000 0001 011B B011	(@HL) '&,\$': HL ←HL+1 '%,\$': ZR ←ZR+1	' ': B4,3=00 '&': B4,3=01 '%': B4,3=10 '\$': B4,3=11
LID8 LID8& LID8% LID8\$	@ZR,@HL 0000 0001 011B B100	(@ZR)8 bits '&,\$': HL ←HL+2 '%,\$': ZR ←ZR+2	' ': B4,3=00 '&': B4,3=01 '%': B4,3=10 '\$': B4,3=11
LID8 LID8& LID8% LID8\$	@HL,@ZR 0000 0001 011B B101	(@HL)8 bits '&,\$': HL ←HL+2 '%,\$': ZR ←ZR+2	' ': B4,3=00 '&': B4,3=01 '%': B4,3=10 '\$': B4,3=11
LIDH LIDH& LIDH% LIDH\$	@ZR,@HL 0000 0001 011B B110	(@ZR)16 bits '&,\$': HL ←HL+4 '%,\$': ZR ←ZR+4	' ': B4,3=00 '&': B4,3=01 '%': B4,3=10 '\$': B4,3=11
LIDH LIDH& LIDH% LIDH\$	@HL,@ZR 0000 0001 011B B111	(@HL)16 bits '&,\$': HL ←HL+4 '%,\$': ZR ←ZR+4	' ': B4,3=00 '&': B4,3=01 '%': B4,3=10 '\$': B4,3=11
LCT LCT#	@ZR,Ry 0000 0001 100B YYYY	(@ZR)8 bits '#': ZR ← (7SEG ← (Ry)) ← ZR+2	' ': B4=0 '#': B4=1
LCB LCB#	@ZR,Ry 0000 0001 101B YYYY	(@ZR)8 bits '#': ZR ← (7SEG ← (Ry)) ← ZR+2	' ': B4=0 '#': B4=1
LCP LCP#	@ZR,Ry 0000 0001 110B YYYY	(@ZR)8 bits '#': ZR ← (Ry) & AC ← ZR+2	' ': B4=0 '#': B4=1
LCD LCD& LCD% LCD\$	@ZR,@HL 0000 0001 111B B000	(@ZR)8 bits '&,\$': HL ← T(@HL) ←HL+1 '%,\$': ZR ←ZR+2	' ': B4,3=00 '&': B4,3=01 '%': B4,3=10 '\$': B4,3=11
LCDH LCDH& LCDH% LCDH\$	@ZR,@HL 0000 0001 111B B100	(@ZR)16 bits '&,\$': HL ← T(@HL) ←HL+2 '%,\$': ZR ←ZR+4	' ': B4,3=00 '&': B4,3=01 '%': B4,3=10 '\$': B4,3=11
LCT LCT& LCT% LCT\$	@ZR,@HL 0000 0001 111B B001	(@ZR)8 bits '&,\$': HL ← (7SEG ← (@HL)) ←HL+1 '%,\$': ZR ←ZR+2	' ': B4,3=00 '&': B4,3=01 '%': B4,3=10 '\$': B4,3=11

Instruction		Machine Code	Function		Flag/Remark
LCB LCB& LCB% LCB\$	@ZR,@HL	0000 0001 111B B010	(@ZR)8 bits '&,\$': HL '%,\$': ZR	← (7SEG ← (@HL)) ← HL+1 ← ZR+2 Blank Zero	' ': B4,3=00 '&': B4,3=01 '%': B4,3=10 '\$': B4,3=11
LCP LCP& LCP% LCP\$	@ZR,@HL	0000 0001 111B B011	(@ZR)8 bits '&,\$': HL '%,\$': ZR	← (@HL) & AC ← HL+1 ← ZR+2	' ': B4,3=00 '&': B4,3=01 '%': B4,3=10 '\$': B4,3=11
LCT	Lz,Ry	0000 001Z ZZZZ YYYY	(Lz)	← (7SEG ← (Ry))	
LCB	Lz,Ry	0000 010Z ZZZZ YYYY	(Lz)	← (7SEG ← (Ry)) Blank Zero	
LCP	Lz,Ry	0000 011Z ZZZZ YYYY	(Lz)	← (Ry) & AC	
LCD LCD#	Lz,@HL	0000 100Z ZZZZ B000	(Lz) '#': HL	← T(@HL) ← HL+1	' ': B3=0 '#': B3=1
LCT LCT#	Lz,@HL	0000 100Z ZZZZ B001	(Lz) '#': HL	← (7SEG ← (@HL)) ← HL+1	' ': B3=0 '#': B3=1
LCB LCB#	Lz,@HL	0000 100Z ZZZZ B010	(Lz) '#': HL	← (7SEG ← (@HL)) ← HL+1 Blank Zero	' ': B3=0 '#': B3=1
LCP LCP#	Lz,@HL	0000 100Z ZZZZ B011	(Lz) '#': HL	← (@HL) & AC ← HL+1	' ': B3=0 '#': B3=1
LCE LCE#	Lz,@HL	0000 100Z ZZZZ 110B	(Lz) '#': HL	← (@HL)8 bits ← HL+2	' ': B0=0 '#': B0=1
LCE LCE#	Lz,@ZR	0000 100Z ZZZZ 111B	(Lz) '#': ZR	← (@ZR)8 bits ← ZR+2	' ': B0=0 '#': B0=1
OPA	Rx	0000 1010 0XXX XXXX	Port(A)	← (Rx)	
OPAS	Rx,D	0000 1011 DXXX XXXX	A1,2,3,4	← (Rx)0,(Rx)1,D,Pulse	
OPB	Rx	0000 1100 0XXX XXXX	Port(B)	← (Rx)	
OPC	Rx	0000 1101 0XXX XXXX	Port(C)	← (Rx)	
OPD	Rx	0000 1110 0XXX XXXX	Port(D)	← (Rx)	
OPE	Rx	0000 1110 1XXX XXXX	Port(E)	← (Rx)	
SMUI	Rx	0000 1111 0XXX XXXX	MUI	← (Rx)	' ': B6=0 '#': B6=1
SMUI SMUI#	@HL	0000 1111 1B00 0000	MUI '#': HL	← (@HL) ← HL+1	
SMUI SMUI#	@ZR	0000 1111 1B10 0000	MUI '#': ZR	← (@ZR) ← ZR+1	
FRQ	D,Rx	0001 00DD 0XXX XXXX	FREQ D=00 D=01 D=10 D=11	← (Rx) & AC : 1/4 Duty : 1/3 Duty : 1/2 Duty : 1/1 Duty	
FRQ FRQ#	D,@HL	0001 01DD 0000 B000	FREQ '#': HL	← T(@HL) ← HL+1	' ': B3=0 '#': B3=1
FRQX	D,X	0001 10DD XXXX XXXX	FREQ	← X	
MVL	Rx	0001 1100 0XXX XXXX	IDBF0~3	← (Rx)	
MRL	Rx	0001 1100 1XXX XXXX	ZRBF0~3	← (Rx)	
MVH	Rx	0001 1101 0XXX XXXX	IDBF4~7	← (Rx)	

Instruction		Machine Code	Function		Flag/Remark
MRH	Rx	0001 1101 1XXX XXXX	ZRBF4~7	← (Rx)	
MVU	Rx	0001 1110 0XXX XXXX	IDBF8~11	← (Rx)	
MRU	Rx	0001 1110 1XXX XXXX	ZRBF8~11	← (Rx)	
MVV	Rx	0001 1111 0XXX XXXX	IDBF12~14	← (Rx)0~2	
MRV	Rx	0001 1111 1XXX XXXX	ZRBF12	← (Rx)0	
ADC ADC*	Rx	0010 000B 0XXX XXXX	AC ‘*’ : (Rx)	← (Rx) + AC + CF ← AC	CF ‘ADC’ : ? = AC
ADC ADC# ADC* ADC*# ADCM ADCM# ADCM* ADCM*#	@HL	0010 000B 1B00 B000	AC ‘*’ : (@HL) ‘#’ : HL	← (@HL) + ? + CF ← AC ← HL+1	‘ADCM’ : ? = MU ‘ ’ : B8=0 ‘*’ : B8=1 ‘ ’ : B6=0 ‘#’ : B6=1
ADC ADC# ADC* ADC*# ADCM ADCM# ADCM* ADCM*#	@HL,DA	0010 000B 1B01 B000	AC ‘*’ : (@HL) ‘#’ : HL	←BCD((@HL)+?+CF) ← AC ← HL+1	‘ADC’ : B3=0 ‘ADCM’ : B3=1
ADC ADC# ADC* ADC*# ADCM ADCM# ADCM* ADCM*#	@ZR	0010 000B 1B10 B000	AC ‘*’ : (@ZR) ‘#’ : ZR	← (@ZR) + ? + CF ← AC ← ZR+1	
ADC ADC# ADC* ADC*# ADCM ADCM# ADCM* ADCM*#	@ZR,DA	0010 000B 1B11 B000	AC ‘*’ : (@ZR) ‘#’ : ZR	←BCD((@ZR)+?+CF) ← AC ← ZR+1	
SBC SBC*	Rx	0010 001B 0XXX XXXX	AC ‘*’ : (Rx)	← (Rx) + ACB + CF ← AC	CF ‘SBC’ : ? = ACB
SBC SBC# SBC* SBC*# SBCM SBCM# SBCM* SBCM*#	@HL	0010 001B 1B00 B000	AC ‘*’ : (@HL) ‘#’ : HL	← (@HL) + ? + CF ← AC ← HL+1	‘SBCM’ : ? = MUB ‘ ’ : B8=0 ‘*’ : B8=1 ‘ ’ : B6=0 ‘#’ : B6=1
SBC	@HL,DA	0010 001B 1B01 B000	AC	←BCD((@HL)+?+CF)	‘SBC’ : B3=0 ‘SBCM’ : B3=1

Instruction		Machine Code	Function		Flag/Remark
SBC# SBC* SBC*# SBCM SBCM# SBCM* SBCM*#			'*' : (@HL) '#' : HL	← AC ← HL+1	
SBC SBC# SBC* SBC*# SBCM SBCM# SBCM* SBCM*#	@ZR	0010 001B 1B10 B000	AC '*' : (@ZR) '#' : ZR	← (@ZR) + ? + CF ← AC ← ZR+1	
SBC SBC# SBC* SBC*# SBCM SBCM# SBCM* SBCM*#	@ZR,DA	0010 001B 1B11 B000	AC '*' : (@ZR) '#' : ZR	←BCD((@ZR)+?+CF) ← AC ← ZR+1	
ADD ADD*	Rx	0010 010B 0XXX XXXX	AC '*' : (Rx)	← (Rx) + AC ← AC	CF
ADD ADD# ADD* ADD*# ADDM ADDM# ADDM* ADDM*#	@HL	0010 010B 1B00 B000	AC '*' : (@HL) '#' : HL	← (@HL) + ? ← AC ← HL+1	'ADD' : ? = AC 'ADDM' : ? = MU ' ' : B8=0 '*' : B8=1 ' ' : B6=0 '#' : B6=1
ADD ADD# ADD* ADD*# ADDM ADDM# ADDM* ADDM*#	@HL,DA	0010 010B 1B01 B000	AC '*' : (@HL) '#' : HL	←BCD((@HL)+?) ← AC ← HL+1	'ADD' : B3=0 'ADDM' : B3=1
ADD ADD# ADD* ADD*# ADDM ADDM# ADDM* ADDM*#	@ZR	0010 010B 1B10 B000	AC '*' : (@ZR) '#' : ZR	← (@ZR) + ? ← AC ← ZR+1	
ADD	@ZR,DA	0010 010B 1B11 B000	AC	←BCD((@ZR)+?)	

Instruction		Machine Code	Function		Flag/Remark
ADD# ADD* ADD*# ADDM ADDM# ADDM* ADDM*#			'*': (@ZR) '#': ZR	← AC ← ZR+1	
SUB SUB*	Rx	0010 011B 0XXX XXXX	AC *'': (Rx)	← (Rx) + ACB + 1 ← AC	CF
SUB SUB# SUB* SUB*# SUBM SUBM# SUBM* SUBM*#	@HL	0010 011B 1B00 B000	AC *'': (@HL) '#': HL	← (@HL) + ? + 1 ← AC ← HL+1	'SUB' : ? = ACB 'SUBM' : ? = MUB '': B8=0 *'': B8=1
SUB SUB# SUB* SUB*# SUBM SUBM# SUBM* SUBM*#	@HL,DA	0010 011B 1B01 B000	AC *'': (@HL) '#': HL	←BCD((@HL)+?+1) ← AC ← HL+1	'SUB' : B3=0 'SUBM' : B3=1
SUB SUB# SUB* SUB*# SUBM SUBM# SUBM* SUBM*#	@ZR	0010 011B 1B10 B000	AC *'': (@ZR) '#': ZR	← (@ZR) + ? + 1 ← AC ← ZR+1	
SUB SUB# SUB* SUB*# SUBM SUBM# SUBM* SUBM*#	@ZR,DA	0010 011B 1B11 B000	AC *'': (@ZR) '#': ZR	←BCD((@ZR)+?+1) ← AC ← ZR+1	
ADN ADN*	Rx	0010 100B 0XXX XXXX	AC *'': (Rx)	← (Rx) + AC ← AC	'': B8=0 *'': B8=1
ADN ADN# ADN* ADN*#	@HL	0010 100B 1B00 0000	AC *'': (@HL) '#': HL	← (@HL) + AC ← AC ← HL+1	'': B6=0 '#': B6=1
ADN ADN# ADN*	@ZR	0010 100B 1B10 0000	AC *'': (@ZR) '#': ZR	← (@ZR) + AC ← AC ← ZR+1	

Instruction		Machine Code	Function		Flag/Remark
ADN*#					
AND AND*	Rx	0010 101B 0XXX XXXX	AC ** : (Rx)	← (Rx) AND AC ← AC	' : B8=0 * : B8=1
AND AND# AND* AND*#	@HL	0010 101B 1B00 0000	AC ** : (@HL) # : HL	← (@HL) AND AC ← AC ← HL+1	' : B6=0 # : B6=1
AND AND# AND* AND*#	@ZR	0010 101B 1B10 0000	AC ** : (@ZR) # : ZR	← (@ZR) AND AC ← AC ← ZR+1	
EOR EOR*	Rx	0010 110B 0XXX XXXX	AC ** : (Rx)	← (Rx) EOR AC ← AC	' : B8=0 * : B8=1
EOR EOR# EOR* EOR*#	@HL	0010 110B 1B00 0000	AC ** : (@HL) # : HL	← (@HL) EOR AC ← AC ← HL+1	' : B6=0 # : B6=1
EOR EOR# EOR* EOR*#	@ZR	0010 110B 1B10 0000	AC ** : (@ZR) # : ZR	← (@ZR) EOR AC ← AC ← ZR+1	
OR OR*	Rx	0010 111B 0XXX XXXX	AC ** : (Rx)	← (Rx) OR AC ← AC	' : B8=0 * : B8=1
OR OR# OR* OR*#	@HL	0010 111B 1B00 0000	AC ** : (@HL) # : HL	← (@HL) OR AC ← AC ← HL+1	' : B6=0 # : B6=1
OR OR# OR* OR*#	@ZR	0010 111B 1B10 0000	AC ** : (@ZR) # : ZR	← (@ZR) OR AC ← AC ← ZR+1	
ADCI	Ry,D	0011 0000 DDDD YYYY	AC	← (Ry) + D + CF	CF
ADCI*	Ry,D	0011 0001 DDDD YYYY	AC,(Ry)	← (Ry) + D + CF	CF
SBCI	Ry,D	0011 0010 DDDD YYYY	AC	← (Ry) + DB + CF	CF
SBCI*	Ry,D	0011 0011 DDDD YYYY	AC,(Ry)	← (Ry) + DB + CF	CF
ADDI	Ry,D	0011 0100 DDDD YYYY	AC	← (Ry) + D	CF
ADDI*	Ry,D	0011 0101 DDDD YYYY	AC,(Ry)	← (Ry) + D	CF
SUBI	Ry,D	0011 0110 DDDD YYYY	AC	← (Ry) + DB + 1	CF
SUBI*	Ry,D	0011 0111 DDDD YYYY	AC,(Ry)	← (Ry) + DB + 1	CF
ADNI	Ry,D	0011 1000 DDDD YYYY	AC	← (Ry) + D	
ADNI*	Ry,D	0011 1001 DDDD YYYY	AC,(Ry)	← (Ry) + D	
ANDI	Ry,D	0011 1010 DDDD YYYY	AC	← (Ry) AND D	
ANDI*	Ry,D	0011 1011 DDDD YYYY	AC,(Ry)	← (Ry) AND D	
EORI	Ry,D	0011 1100 DDDD YYYY	AC	← (Ry) EOR D	
EORI*	Ry,D	0011 1101 DDDD YYYY	AC,(Ry)	← (Ry) EOR D	
ORI	Ry,D	0011 1110 DDDD YYYY	AC	← (Ry) OR D	
ORI*	Ry,D	0011 1111 DDDD YYYY	AC,(Ry)	← (Ry) OR D	
INC*	Rx	0100 0000 0XXX XXXX	AC,(Rx)	← (Rx) + 1	' : B6=0 # : B6=1
INC*	@HL	0100 0000 1B00 0000	AC,(@HL)	← (@HL) + 1	CF

Instruction		Machine Code	Function		Flag/Remark
INC*#			'#' : HL	← HL+1	
INC* INC*#	@ZR	0100 0000 1B10 0000	AC,(@ZR) '#' : ZR	← (@ZR) + 1 ← ZR+1	
DEC*	Rx	0100 0001 0XXX XXXX	AC,(Rx)	← (Rx) - 1	'' : B6=0 '#' : B6=1 CF
DEC* DEC*#	@HL	0100 0001 1B00 0000	AC,(@HL) '#' : HL	← (@HL) - 1 ← HL+1	
DEC* DEC*#	@ZR	0100 0001 1B10 0000	AC,(@ZR) '#' : ZR	← (@ZR) - 1 ← ZR+1	
MULH	Rx	0100 0010 0XXX XXXX	MU AC	←(Hex. : H) MUI x (Rx) ←(Hex. : L) MUI x (Rx)	'' : B6=0 '#' : B6=1
MULH MULH#	@HL	0100 0010 1B00 0000	MU AC '#' : HL	←(Hex. : H) MUI x (@HL) ←(Hex. : L) MUI x (@HL) ← HL+1	
MULH MULH#	@ZR	0100 0010 1B10 0000	MU AC '#' : ZR	←(Hex. : H) MUI x (@ZR) ←(Hex. : L) MUI x (@ZR) ← ZR+1	
MULD	Rx	0100 0011 0XXX XXXX	MU AC	←(Dec. : H) MUI x (Rx) ←(Dec. : L) MUI x (Rx)	'' : B6=0 '#' : B6=1
MULD MULD#	@HL	0100 0011 1B00 0000	MU AC '#' : HL	←(Dec. : H) MUI x (@HL) ←(Dec. : L) MUI x (@HL) ← HL+1	
MULD MULD#	@ZR	0100 0011 1B10 0000	MU AC '#' : ZR	←(Dec. : H) MUI x (@ZR) ←(Dec. : L) MUI x (@ZR) ← ZR+1	
MWM	Rm, Ry	0100 0100 MMMM YYYY	Rm	← Ry	
MMW	Ry, Rm	0100 0101 MMMM YYYY	AC, Ry	← Rm	
IPA	Rx	0100 0110 0XXX XXXX	AC,(Rx)	← Port(A)	
IPB	Rx	0100 0110 1XXX XXXX	AC,(Rx)	← Port(B)	
IPC	Rx	0100 0111 0XXX XXXX	AC,(Rx)	← Port(C)	
LSP	Rx	0100 0111 1XXX XXXX	AC,(Rx)	← STACK Point	
IPD	Rx	0100 1000 0XXX XXXX	AC,(Rx)	← Port(D)	
IPE	Rx	0100 1000 1XXX XXXX	AC,(Rx)	← Port(E)	
LDS LDS#	@HL,D	0100 1001 1B00 DDDD	AC, (@HL) '#' : HL	← D ← HL+1	
LDS LDS#	@ZR,D	0100 1001 1B10 DDDD	AC,(@ZR) '#' : ZR	← D ← ZR+1	'' : B6=0 '#' : B6=1
MAF	Rx	0100 1010 0XXX XXXX	AC,(Rx)	← STS1	B3 : CF B2 : ZERO B1 : SCF12(CX2) B0 : SCF11(CX)
RTM2L	Rx	0100 1010 1XXX XXXX	AC,(Rx)	← TM2(0~3)	
MSB	Rx	0100 1011 0XXX XXXX	AC,(Rx)	← STS2	B3 : SCF3(DPT) B2 : SCF2(HRx) B1 : SCF1(CPT) B0 : BCF

Instruction		Machine Code	Function		Flag/Remark
RTM21	Rx	0100 1011 1XXX XXXX	AC,(Rx)	← TM2(4,5),1(0,1)	
MSC	Rx	0100 1100 0XXX XXXX	AC,(Rx)	← STS3	B3 : SCF7(PDV) B2 : PH15 B1 : SCF5(TM1) B0 : SCF4(INT)
RTM1H	Rx	0100 1100 1XXX XXXX	AC,(Rx)	← TM1(2~5)	
MCX	Rx	0100 1101 0XXX XXXX	AC,(Rx)	← STS3X	B3 : No Use B2 : SCF0(APT) B1 : SCF6(TM2) B0 : SCF8(SKI)
RTM3L	Rx	0100 1101 1XXX XXXX	AC,(Rx)	← TM3(0~3)	
MSD	Rx	0100 1110 0XXX XXXX	AC,(Rx)	← STS4	B3 : No Use B2 : RFOVF B1 : WDF B0 : CSF
RTM31	Rx	0100 1110 1XXX XXXX	AC,(Rx)	← TM3(4,5), 1(0,1)	
MDX	Rx	0100 1111 0XXX XXXX	AC,(Rx)	← STS4X	B3 : SCF10(TM3) B2 : INT B1 : CX2 B0 : CX
MKI	Rx	0100 1111 1XXX XXXX	AC,(Rx)	← STS5(KI4~1)	
SR0	Rx	0101 0000 0XXX XXXX	ACn, (Rx)n AC3, (Rx)3	← (Rx)(n+1) ← 0	
SR1	Rx	0101 0000 1XXX XXXX	ACn, (Rx)n AC3, (Rx)3	← (Rx)(n+1) ← 1	
SL0	Rx	0101 0001 0XXX XXXX	ACn, (Rx)n AC0, (Rx)0	← (Rx)(n-1) ← 0	
SL1	Rx	0101 0001 1XXX XXXX	ACn, (Rx)n AC0, (Rx)0	← (Rx)(n-1) ← 1	
RRC	Rx	0101 0010 0XXX XXXX	ACn, (Rx)n AC3, (Rx)3 CF	← (Rx)(n+1) ← CF ← (Rx)0	CF ' : B6=0 # : B6=1
RRC RRC#	@HL	0101 0010 1B00 0000	ACn, (@HL)n AC3, (@HL)3 CF #: HL	← (@HL)(n+1) ← CF ← (@HL)0 ← HL+1	
RRC RRC#	@ZR	0101 0010 1B10 0000	ACn, (@ZR)n AC3, (@ZR)3 CF #: ZR	← (@HL)(n+1) ← CF ← (@ZR)0 ← ZR+1	
RLC	Rx	0101 0011 0XXX XXXX	ACn, (Rx)n AC0, (Rx)0 CF	← (Rx)(n-1) ← CF ← (Rx)3	CF ' : B6=0 # : B6=1
RLC RLC#	@HL	0101 0011 1B00 0000	ACn, (@HL)n AC0, (@HL)0 CF #: HL	← (@HL)(n-1) ← CF ← (@HL)3 ← HL+1	
RLC RLC#	@ZR	0101 0011 1B10 0000	ACn, (@ZR)n AC0, (@ZR)0 CF #: ZR	← (@HL)(n-1) ← CF ← (@ZR)3 ← ZR+1	
DAA		0101 0100 0000 0000	AC	← BCD(CF,AC) for add.	CF

Instruction		Machine Code		Function	Flag/Remark
DAA*	Rx	0101 0101 0XXX XXXX	AC,(Rx)	← BCD(CF,AC) for add.	'': B6=0 #: B6=1
DAA*	@HL	0101 0101 1B00 0000	AC,(@HL)	← BCD(CF,AC) for add.	
DAA*#			# : HL	←HL+1	
DAA*	@ZR	0101 0101 1B10 0000	AC,(@ZR)	← BCD(CF,AC) for add.	
DAA*#			# : ZR	←ZR+1	
DAS		0101 0110 0000 0000	AC	← BCD(CF,AC) for sub.	CF
DAS*	Rx	0101 0111 0XXX XXXX	AC,(Rx)	← BCD(CF,AC) for sub.	'': B6=0 #: B6=1
DAS*	@HL	0101 0111 1B00 0000	AC,(@HL)	← BCD(CF,AC) for sub.	
DAS*#			# : HL	←HL+1	
DAS*	@ZR	0101 0111 1B10 0000	AC,(@ZR)	← BCD(CF,AC) for sub.	
DAS*#			# : ZR	←ZR+1	
LDS	Rx,D	0101 1DDD DXXX XXXX	AC,(Rx)	← D	
LDH	Rx,@HL	0110 000B 0XXX XXXX	AC,(Rx)	← H(T(@HL))	'': B8=0
LDH*			*: HL	← HL + 1	*: B8=1
LDL	Rx,@HL	0110 001B 0XXX XXXX	AC,(Rx)	← L(T(@HL))	'': B8=0
LDL*			*: HL	← HL + 1	*: B8=1
MRF1	Rx	0110 0000 1XXX XXXX	AC,(Rx)	← RFC3-0	
MRF2	Rx	0110 0001 1XXX XXXX	AC,(Rx)	← RFC7-4	
MRF3	Rx	0110 0010 1XXX XXXX	AC,(Rx)	← RFC11-8	
MRF4	Rx	0110 0011 1XXX XXXX	AC,(Rx)	← RFC15-12	
LDS8	@HL,D	0110 010B DDDD	(@HL)	← D(8 bits)	#0
LDS8#		DDDD	#: HL	← HL+2	
LDS8	@ZR,D	0110 011B DDDD	(@ZR)	← D(8 bits)	'': B8=0
LDS8#		DDDD	#: ZR	← ZR+2	#: B8=1
STA	Rx	0110 1000 0XXX XXXX	(Rx)	← AC	'': B6=0 #: B6=1
STA	@HL	0110 1000 1B00 0000	(@HL)	← AC	
STA#			# : HL	← HL+1	
STA	@ZR	0110 1000 1B10 0000	(@ZR)	← AC	
STA#			# : ZR	← ZR+1	
MMH	Rx	0110 1001 0XXX XXXX	AC,(Rx)	← MU	'': B6=0 #: B6=1
MMH	@HL	0110 1001 1B00 0000	AC,(@HL)	← MU	
MMH#			#: HL	← HL+1	
MMH	@ZR	0110 1001 1B10 0000	AC,(@ZR)	← MU	
MMH#			#: ZR	← ZR+1	
MRW	@ZR,Rx	0110 1010 BXXX XXXX	AC,(@ZR)	← (Rx)	'': B7=0
MRW#			# : ZR	←ZR+1	#: B7=1
MWR	Rx,@ZR	0110 1011 BXXX XXXX	AC,(Rx)	← (@ZR)	'': B7=0
MWR#			# : ZR	←ZR+1	#: B7=1
LDA	Rx	0110 1100 0XXX XXXX	AC	← (Rx)	'': B6=0 #: B6=1
LDA	@HL	0110 1100 1B00 0000	AC	← (@HL)	
LDA#			#: HL	← HL+1	

Instruction		Machine Code	Function		Flag/Remark
LDA LDA#	@ZR	0110 1100 1B10 0000	AC ‘#’: ZR	← (@ZR) ← ZR+1	
MRA	Rx	0110 1101 0XXX XXXX	CF	← (Rx)3	
MHL	X	0110 1101 10XX XX00	IDBF0~14	← (Rx)16 bits	Rx : 0 0000 10XX XX00b~ 0 0000 10XX XX11b
RHL	X	0110 1101 10XX XX01	(Rx)16 bits	← IDBF0~14	Rx : 0 0000 10XX XX00b~ 0 0000 10XX XX11b
MZR	X	0110 1101 10XX XX10	ZRBF0~12	← (Rx)16 bits	Rx : 0 0000 11XX XX00b~ 0 0000 11XX XX11b
RZR	X	0110 1101 10XX XX11	(Rx)16 bits	← ZRBF0~12	Rx : 0 0000 11XX XX00b~ 0 0000 11XX XX11b
MRW MRW#	@HL,Rx	0110 1110 BXXX XXXX	AC,(@HL) ‘#’: HL	← (Rx) ← HL+1	‘’: B7=0 ‘#’: B7=1
MWR MWR#	Rx,@HL	0110 1111 BXXX XXXX	AC,(Rx) ‘#’: HL	← (@HL) ← HL+1	‘’: B7=0 ‘#’: B7=1
MRW	Ry,Rx	0111 0YYY YXXX XXXX	AC,(Ry)	← (Rx)	
MWR	Rx,Ry	0111 1YYY YXXX XXXX	AC,(Rx)	← (Ry)	
JB0	X	1000 0XXX XXXX XXXX	PC	← X	if AC0 = 1
JB1	X	1000 1XXX XXXX XXXX	PC	← X	if AC1 = 1
JB2	X	1001 0XXX XXXX XXXX	PC	← X	if AC2 = 1
JB3	X	1001 1XXX XXXX XXXX	PC	← X	if AC3 = 1
JNZ	X	1010 0XXX XXXX XXXX	PC	← X	if AC ≠ 0
JNC	X	1010 1XXX XXXX XXXX	PC	← X	if CF = 0
JZ	X	1011 0XXX XXXX XXXX	PC	← X	if AC = 0
JC	X	1011 1XXX XXXX XXXX	PC	← X	if CF = 1
CALL	X	1100 0XXX XXXX XXXX	STACK PC	← PC + 1 ← X	
JMP	X	1100 1XXX XXXX XXXX	PC	← X	
CPZR	X	1101 0101 XXXX XXXX	(PC+1)	← force “NOP” if X7~0=ZRBF7~0	Can’t set ERX/ERY/ ELZ/CLPG to PC+1
SRY	X	1101 000X XXXX XXXX	X8~0	:Set Ry Page (0~6,8~ 17Fh) for Rx 0~17FFh	Inserted by Compiler
ERY	X	1101 001X XXXX XXXX	X8~0	:Enable Ry Page (0~6,8~ 17Fh) for Rx 0~17FFh Set & Lock	1. Before executing “CLPG (X1=1)”, Page still can be changed by executing “ERY” again. 2. Between jump location, can’t have any

Instruction		Machine Code		Function	Flag/Remark
					“ERY/ERX/ELZ/CLPG” instructions. 3. Interrupt will be masked by hardware till all page settings are cleared by “CLPG”.
SRX	X	1101 0100 00XX XXXX	X6~0	:Set Rx Page (1~2Fh)	Inserted by Compiler
ERX	X	1101 0110 00XX XXXX	X6~0	:Enable Rx Page (1~2Fh) Set & Lock	1. Before executing “CLPG (X0=1)”, Page still can be changed by executing “ERX” again. 2. Between jump location, can't have any “ERY/ERX/ELZ/CLPG” instructions 3. Interrupt will be masked by hardware till all page settings are cleared by “CLPG”.
SLZ	X	1101 0100 0100 00XX	X1~0	:Set Lz Page(1~3h)	Inserted by Compiler
ELZ	X	1101 0110 0100 00XX	X1~0	:Enable Lz Page(1~3h) Set & Lock	1. Before executing “CLPG (X2=1)”, Page still can be changed by executing “ELZ” again. 2. Between jump location, can't have any “ERY/ERX/ELZ/CLPG” instructions. 3. Interrupt will be masked by hardware till all page settings are cleared by “CLPG”.
SPBK	X	1101 0110 1000 XXXX	X3~0	:Set POM BANK X=00~0FH	Inserted by Compiler
CLPG	X	1101 0110 1010 1XXX	X2=1 X1=1 X0=1	:Release Lz Page Lock :Release Ry Page Lock :Release Rx Page Lock	
T2M3X	X	1101 0111 00XX XXXX	X5~0	: Set Counter 17~12 (Timer3) Value	If TM3 is merged into TM2
			SD15~12=	:Ctm=INT/CX2/CX	Add “SETDAT SD”

Instruction		Machine Code	Function		Flag/Remark
			1010~1000 0111~0100 0011~0000	:Ctm=PH13/11/7/5 :Ctm=FREQ/PH15/3/9/	to the next address
			SD11~6	: Set Counter 11~6 (Timer1) Value	if TM1 is merged into TM2
			SD5~0	: Set Counter 5~0 (Timer2) Value	
T1XH		1101 0111 0100 0000	SD15~12= 1010~1000 0111~0100 0011~0000	:Ctm=INT/CX2/CX :Ctm=PH13/11/7/5 :Ctm=FREQ/PH15/3/9/	Add "SETDAT SD" to the next address
			SD11~6	: Set Counter 5~0 (Timer1) Value	
T1RH		1101 0111 0100 0010	Timer1	← (Rx)16 bits	Add "SETDAT SD" to the next address
			SD12~0	:Rx Address (SD1,0=00b) for 16bits data mode	SD:0000~17FFH
			(Rx)15~12= 1010~1000 0111~0100 0011~0000	:Ctm=INT/CX2/CX :Ctm=PH13/11/7/5 :Ctm=FREQ/PH15/3/9/	
			(Rx)11~6	: Set Counter 5~0 (Timer1) Value	
T2XH		1101 0111 0100 0100	SD15~12= 1010~1000 0111~0100 0011~0000	:Ctm=INT/CX2/CX :Ctm=PH13/11/7/5 :Ctm=FREQ/PH15/3/9/	Add "SETDAT SD" to the next address
			SD11~6	: Set Counter 11~6 (Timer1) Value	if TM1 is merged into TM2
			SD5~0	: Set Counter 5~0 (Timer2) Value	
T2RH		1101 0111 0100 0110	Timer2	← (Rx)16 bits	Add "SETDAT SD" to the next address
			SD12~0	:Rx Address (SD1,0=00b) for 16 bits data mode	SD:0000~17FFH
			(Rx)15~12= 1010~1000 0111~0100 0011~0000	:Ctm=INT/CX2/CX :Ctm=PH13/11/7/5 :Ctm=FREQ/PH15/3/9/	
			(Rx)11~6	: Set Counter 11~6 (Timer1) Value	if TM1 is merged into TM2
			(Rx)5~0	: Set Counter 5~0 (Timer2) Value	

Instruction		Machine Code	Function		Flag/Remark
T3XH		1101 0111 0100 1000	SD15~12= 1010~1000 0111~0100 0011~0000	:Ctm=INT/CX2/CX :Ctm=PH13/11/7/5 :Ctm=FREQ/PH15/3/9/	Add "SETDAT SD" to the next address
			SD11~6	: Set Counter 11~6 (Timer1) Value	if TM1 is merged into TM3
			SD5~0	: Set Counter 5~0 (Timer3) Value	
T3RH		1101 0111 0100 1010	Timer3	← (Rx)16 bits	Add "SETDAT SD" to the next address
			SD12~0	:Rx Address (SD1,0=00b) for 16 bits data mode	SD:0000~17FFH
			(Rx)15~12= 1010~1000 0111~0100 0011~0000	:Ctm=INT/CX2/CX :Ctm=PH13/11/7/5 :Ctm=FREQ/PH15/3/9/	
			(Rx)11~6	: Set Counter 11~6 (Timer1) Value	if TM1 is merged into TM3
			(Rx)5~0	: Set Counter 5~0 (Timer3) Value	
SPKXH	D	1101 0111 0100 110D	KO16~1	← SETDAT SD(16 bits)	Add "SETDAT SD" to the next address
			D=1	: KEY_S released by scanning cycle	
			D=0	: KEY_S released by normal key scanning	
			SD15~0	: Enable KO16~1=1	
SPKRH	D	1101 0111 0100 111D	KO16~1	← (Rx)16 bits	Add "SETDAT SD" to the next address
			D=1	: KEY_S released by scanning cycle	SD:0000~17FFH
			D=0	: KEY_S released by normal key scanning	
			(Rx)15~0	: Enable KO16~1=1	
LDSH	@HL	1101 0111 0101 100B	(@HL)16 bits	← SETDAT SD(16 bits)	Add "SETDAT SD" to the next address
LDSH#			'#': HL	← HL+4	' ': B0=0
LDSH	@ZR	1101 0111 0101 101B	(@ZR)16 bits	← SETDAT SD(16 bits)	'#': B0=1
LDSH#			'#': ZR	← ZR+4	
SHLX		1101 0111 0101 1100	IDBF14~0	← SETDAT SD(16 bits) SD : 0000~7FFFH	Add "SETDAT SD" to the next address
SZRX		1101 0111 0101 1101	ZRBF12~0	← SETDAT SD(16 bits) SD : 0000~17FFFH	Add "SETDAT SD" to the next address
CPHLH		1101 0111 0101 1110	(PC+2)	← force "NOP" if SETDAT SD(16 bits) = IDBF14~0	Add "SETDAT SD" to the next address Can't set ERX/ERY/

Instruction	Machine Code	Function	Flag/Remark	
CPZRH	1101 0111 0101 1111	(PC+2) ← force "NOP" if SETDAT SD(16 bits) = ZRBF12~0	ELZ/CLPG to PC+2 Add "SETDAT SD" to the next address Can't set ERX/ERY/ ELZ/CLPG to PC+2	
CAC	X 1101 0111 0110 XXXX	X>=AC: STACK PC(SET) PC X<AC: PC	← PC+X+2 ← PC+AC+1 ← SETDAT SD(16 bits) ← PC+X+2	Add "SETDAT SD" to the next X(<16) Addresses range
JAC	X 1101 0111 0111 XXXX	X>=AC: PC(SET) PC X<AC: PC	← PC+AC+1 ← SETDAT SD(16 bits) ← PC+X+2	Add "SETDAT SD" to the next X(<16) Addresses range
T1TH T1TH#	@HL 1101 0111 1000 B000	Timer1 '#' : HL TD15~12= 1010~1000 0111~0100 0011~0000 TD11~6	← T(@HL)16 bits ← HL+2 :Ctm=INT/CX2/CX :Ctm=PH13/11/7/5 :Ctm=FREQ/PH15/3/9/ : Set Counter 11~6 (Timer1) Value	' ' : B3=0 '#' : B3=1
T2TH T2TH#	@HL 1101 0111 1001 B000	Timer2(2->1) '#' : HL TD15~12= 1010~1000 0111~0100 0011~0000 TD11~6 TD5~0	← T(@HL)16 bits ← HL+2 :Ctm=INT/CX2/CX :Ctm=PH13/11/7/5 :Ctm=FREQ/PH15/3/9/ : Set Counter 11~6 (Timer1) Value : Set Counter 5~0 (Timer2) Value	' ' : B3=0 '#' : B3=1 if TM1 is merged into TM2
T3TH T3TH#	@HL 1101 0111 1010 B000	Timer3(3->1) '#' : HL TD15~12= 1010~1000 0111~0100 0011~0000 TD11~6 TD5~0	← T(@HL)16 bits ← HL+2 :Ctm=INT/CX2/CX :Ctm=PH13/11/7/5 :Ctm=FREQ/PH15/3/9/ : Set Counter 11~6 (Timer1) Value : Set Counter 5~0 (Timer3) Value	' ' : B3=0 '#' : B3=1 if TM1 is merged into TM3

Instruction		Machine Code	Function		Flag/Remark
SPKTH SPKTH#	D,@HL	1101 0111 1011 B00X	KO16~1 # : HL D=1 D=0 TD15~0	← T(@HL)16 bits ← HL+2 : KEY_S released by scanning cycle : KEY_S released by normal key scanning : Enable KO16~1=1	' : B3=0 # : B3=1
RVL	Rx	1101 1000 0XXX XXXX	AC _i (Rx)	← IDBF0~3	
RRL	Rx	1101 1000 1XXX XXXX	AC _i (Rx)	← ZRBF0~3	
RVH	Rx	1101 1001 0XXX XXXX	AC _i (Rx)	← IDBF4~7	
RRH	Rx	1101 1001 1XXX XXXX	AC _i (Rx)	← ZRBF4~7	
RVU	Rx	1101 1010 0XXX XXXX	AC _i (Rx)	← IDBF8~11	
RRU	Rx	1101 1010 1XXX XXXX	AC _i (Rx)	← ZRBF8~11	
RVV	Rx	1101 1011 0XXX XXXX	AC _i (Rx)0~2	← IDBF12~14	
RRV	Rx	1101 1011 1XXX XXXX	AC _i (Rx)0	← ZRBF12	
TM3	Rx	1101 1100 0XXX XXXX	Timer3	← (Rx) & AC	
TM3 TM3#	@HL	1101 1101 0000 B000	Timer3 # : HL	← T(@HL) ← HL+1	' : B3=0 # : B3=1
TM3X	X	1101 111X XXXX XXXX	X8,7,6=111 X8,7,6=110 X8,7,6=101 X8,7,6=100 X8,7,6=011 X8,7,6=010 X8,7,6=001 X8,7,6=000 X5~0	: Ctm = PH13 : Ctm = PH11 : Ctm = PH7 : Ctm = PH5 : Ctm = FREQ : Ctm = PH15 : Ctm = PH3 : Ctm = PH9 : Set Timer3 Value	
TMS	Rx	1110 0000 0XXX XXXX	AC3,2 = 11 AC3,2 = 10 AC3,2 = 01 AC3,2 = 00 AC1,0,PB3~0	: Ctm = FREQ : Ctm = PH15 : Ctm = PH3 : Ctm = PH9 : Set Timer1 Value	
TMS TMS#	@HL	1110 0001 0000 B000	Timer1 # : HL	← T(@HL) ← HL+1	' : B3=0 # : B3=1
TMSX	X	1110 001X XXXX XXXX	X8,7,6=111 X8,7,6=110 X8,7,6=101 X8,7,6=100 X8,7,6=011 X8,7,6=010 X8,7,6=001 X8,7,6=000 X5~0	: Ctm = PH13 : Ctm = PH11 : Ctm = PH7 : Ctm = PH5 : Ctm = FREQ : Ctm = PH15 : Ctm = PH3 : Ctm = PH9 : Set Timer1 Value	
TM2	Rx	1110 0100 0XXX XXXX	Timer2	← (Rx) & AC	
TM2 TM2#	@HL	1110 0101 0000 B000	Timer2 # : HL	← T(@HL) ← HL+1	' : B3=0 # : B3=1
TM2X	X	1110 011X XXXX XXXX	X8,7,6=111 X8,7,6=110 X8,7,6=101 X8,7,6=100 X8,7,6=011 X8,7,6=010 X8,7,6=001	: Ctm = PH13 : Ctm = PH11 : Ctm = PH7 : Ctm = PH5 : Ctm = FREQ : Ctm = PH15 : Ctm = PH3	

Instruction		Machine Code	Function		Flag/Remark
			X8,7,6=000 X5~0	: Ctm = PH9 : Set Timer2 Value	
SHE	X	1110 1000 X0XX XXX0	X7 X5 X4 X3 X2 X1	: Enable HEF7 : Enable HEF5 : Enable HEF4 : Enable HEF3 : Enable HEF2 : Enable HEF1	TMR3 KEY_S TMR2 PDV INT TMR1
SIE*	X	1110 1001 XXXX XXXX	X7 X6 X5 X4 X3 X2 X1 X0	: Enable IEF7 : Enable IEF6 : Enable IEF5 : Enable IEF4 : Enable IEF3 : Enable IEF2 : Enable IEF1 : Enable IEF0	TMR3 RFC KEY_S TMR2 PDV INT TMR1 A,C,DPT
PLC	X	1110 101X XXXX XXXX	X8 X7-0	: Reset PH15~11 : Reset HRF7-0	
SRF	X	1110 1100 00XX XXXX	X5~0	:Enable RFC5~0 Output	
SRE	X	1110 1101 0X0X X000	X6 X4 X3	:Enable SRF6(A port) :Enable SRF4(C port) :Enable SRF3(D port)	
FAST		1110 1110 0000 0000	SCLK	: High Speed Clock	
SLOW		1110 1110 1000 0000	SCLK	: Low Speed Clock	
CPHL	X	1110 1111 XXXX XXXX	(PC+1)	← force "NOP" if X7~0=IDBF7~0	Can't set ERX/ERY/ ELZ/CLPG to PC+1
SPK	Rx	1111 0000 0XXX XXXX	KO1~16	← (Rx) & AC	
SPK	@HL	1111 0001 0000 B000	KO1~16	← T (@HL)	' ' : B3=0
SPK#			'#': HL	← HL+1	'#': B3=1
SPKX	X	1111 0010 XXXX XXXX	X6=1 X6=0 X7,5,4=000 X7,5,4=001 X7,5,4=010 X7,5,4=10X X7,5,4=110 X7,5,4=111	: KEY_S released by scanning cycle : KEY_S released by normal key scanning : Set one of KO1~16 =1 by X3~0 : Set all = 1 : Set all Hi-z : Set eight of KO1~16 =1 by X3 X3=0 => KO1~8 X3=1 => KO9~16 : Set four of KO1~16 =1 by X3,2 X3,2=00 => KO1~4 X3,2=01 => KO5~8 X3,2=10 => KO9~12 X3,2=11 => KO13~16 : Set two of KO1~16 =1 by X3,2,1 X3~1=000=>KO1,2 X3~1=001=>KO3,4 X3~1=010=>KO5,6 X3~1=011=>KO7,8 X3~1=100=>KO9,10 X3~1=101=>KO11,12	

Instruction		Machine Code		Function	Flag/Remark
				X3~1=110=>KO13,14 X3~1=111=>KO15,16	
RTS		1111 0100 0000 0000	PC	← STACK (CALL Return)	
SBZ	X	1111 0100 0010 00XX	X1=0 X1=1	<set BZB Pad> :BZB :FREQB only	Initial
			X0=0 X0=1	<set BZ Pad> :BZ :FREQ only	Initial
STM	X	1111 0100 0011 00XX	X1,0=00 X1,0=01 X1,0=10 X1,0=11	:TM1,2,3 is independent : TM2(2=>1) : TM3(3=>1) : TM2(2=>1=>3)	Initial(X1,0=00)
DISTM	X	1111 0100 0011 1XXX	X2~0	: Disable TM3~1 Count	
SCNT	X	1111 0100 01XX XXXX	X5=0 X5=1	: Enable CX set : Enable CX2 set	
			X4=0 X4=1	Counter clock source for not CX/2 control Mode : CX/2 : FREQ	initial
			X3,2=00 X3,2=01 X3,2=10 X3,2=11	Control Mode : Softwave : TM2 : CX/2 – One Cycle : CX/2 – High Level	
			X1,0=00 X1,0=01 X1,0=10 X1,0=11	Counter for CX/2 : RFC : TM1 : TM2 : TM3	initial
SCC	X	1111 0100 1XXX XXXX	X6 = 1 X6 = 0 X5 = 1 X4 = 1 X3 = 1 X2,1,0=001 X2,1,0=010 X2,1,0=100	: Cfq = BCLK : Cfq = PH0 :Set P(A) Cch :Set P(C) Cch : Set P(D) Cch : Cch = PH10 : Cch = PH8 : Cch = PH6	
SCA	X	1111 0101 00XX X000	X5 X4 X3	: Enable SEF5(A1-4) : Enable SEF4(C1-4) : Enable SEF3(D1-4)	
SPE	X	1111 0101 010X XXXX	X4 X3~0	: Set E4-1 Pull-Low : Set E4-1 I/O	
SCX	X	1111 0101 0110 00XX	X1 X0	: Enable SEF1(CX2) : Enable SEF0(CX)	
SPA	X	1111 0101 100X XXXX	X4 X3~0	: Set A4-1 Pull-Low : Set A4-1 I/O	
SPB	X	1111 0101 101X XXXX	X4 X3~0	: Set B4-1 Pull-Low : Set B4-1 I/O	
SPC	X	1111 0101 110X XXXX	X4	: Set C4-1 Pull-Low / Low-Level-Hold	

Instruction		Machine Code	Function		Flag/Remark
			X3-0	: Set C4-1 I/O	
SPD	X	1111 0101 111X XXXX	X4 X3-0	: Set D4-1 Pull-Low : Set D4-1 I/O	
SF	X	1111 0110 XXXX XXXX	X7 X6 X5 X4 X3 X2 X1 X0	: Reload 1 Set : Reload 3 Set : Enable all Timer Counter update & latch : WDT Enable : HALT after EL : EL LIGHT On : BCF Set : CF Set	
RF	X	1111 0111 XXXX 0XXX	X7 X6 X5 X4 X2 X1 X0	: Reload 1 Reset : Reload 3 Reset : Disable all Timer Counter latch : WDT Reset : EL LIGHT Off : BCF Reset : CF Reset	
ELC	X	1111 10XX XXXX XXXX	(ELP) X8,7,6=111 X8,7,6=110 X8,7,6=101 X8,7,6=100 X8,7,6=011 X8,7,6=000 X9,5,4=101 X9,5,4=100 X9,5,4=x11 X9,5,4=x10 X9,5,4=001 X9,5,4=000 (ELC) X3,2=11 X3,2=10 X3,2=01 X3,2=00 X1,0=11 X1,0=10 X1,0=01 X1,0=00	BCLK/8 BCLK/4 BCLK/2 BCLK FREQB PH0 2/3 3/4 1/1 1/2 1/3 1/4 PH5 PH6 PH7 PH8 1/1 1/2 1/3 1/4	
ALM	X	1111 110X XXXX XXXX	X8,7,6=111 X8,7,6=100 X8,7,6=011 X8,7,6=010 X8,7,6=001 X8,7,6=000 X5~0	: FREQ : DC1 : PH3 : PH4 : PH5 : DC0 ← PH15~10	
SF2	X	1111 1110 0XXX XXXX	X6 X5 X3 X2	: Enable CX2 Counter : Enable CX Counter : Enable INT powerful Pull-low : Close all Segments	

Instruction		Machine Code	Function	Flag/Remark
			X1 X0	: Dis-ENX Set : Reload 2 Set
RF2	X	1111 1110 1XXX XXXX	X6 X5 X3 X2 X1 X0	:Disable CX2 Counter :Disable CX Counter : Disable INT powerful Pull-low : Release Segments : Dis-ENX Reset : Reload 2 Reset
HALT		1111 1111 0000 0000	Halt Operation	
STOP		1111 1111 1000 0000	Stop Operation	

Symbol Description

AC	: Accumulator	D	: Immediate Data
ACB	: Invert of Accumulator	DB	: Invert of Immediate Data
ACn	: Accumulator bit n	PC	: Program Counter
X	: Address or Set data	CF	: Carry Flag
Rx	: Address of Data RAM	ZERO	: Zero Flag
(Rx)n	: Bit n of (Rx)	WDF	: Watch-Dog Timer Enable Flag
Ry	: Address of the working register	PDV	: Pre-Divider
BCF	: Back-up Flag	BCLK	: System clock stop only in STOP condition
IEFn	: Interrupt Enable Flag	SEFn	: Switch Enable Flag
HRFn	: HALT Release Flag	SRFn	: STOP Release Enable Flag
HEFn	: HALT Release Enable Flag	SCFn	: Start Condition Flag
TMR	: Timer Overflow Release Flag	Cch	: Clock Source of Chattering Detector
Ctm	: Clock Source of Timer	Cfq	: Clock Source of Frequency Generator
Lz	: Address of LCD data	FREQ	: Frequency Generator setting Value
RFOVF	: RFC Overflow Flag	()	: Content of Address Register
MUI	: Multiplication Input Register	MU	: Multiplication High nibble Result Register
@HL	: Address assigned by Index Register	HL	: Index Register
@ZR	: Address assigned by Index2 Register	ZR	: Index2 Register
H(T@HL)	: High Nibble of Index ROM data	L(T@HL)	: Low Nibble of Index ROM Data
IDBF	: Content of Index Register	ZRBF	: Content of Index2 Register
T@HL	: Index ROM address assigned by Index Register		
CSF	: Clock Source Flag	DA	: BCD for result

(@HL)/(@ZR): 4 bits data type for Data RAM
 (@HL)8 bits/(@ZR)8 bits: 8 bits data type for Data RAM
 (@HL)16 bits/(@ZR)16 bits: 16 bits data type for Data RAM
 T(@HL): 8 bits data type for Index ROM
 T(@HL)16 bits: 16 bits data type for Index ROM
 HL+1 / ZR+1: +1 to index address bit0
 HL+2 / ZR+2: mask index address bit0, and +1 to bit1
 HL+4 / ZR+4: mask index address bit1&0, and +1 to bit2

MWM/MMW Rm Assignment

Rm	R/W	Instruction	BIT3	BIT2	BIT1	BIT0
0~8	Don't Use					
9	R	MMW Ry, 9	LVR2F	LBD4	-	LBF
	W	MWM 9, Ry	CLRLVR2 / LVR2RLS		0	ENLBD
A	R	MMW Ry, A	VDL3	VDL2	VDL1	VDL0
	W	MWM A, Ry				
B	R	MMW Ry, B	LBD3	LBD2	LBD1	LBD0
	W	MWM B, Ry				
C~E	Don't Use					
F	R	MMW Ry, F	VDX3	VDX2	VDX1	VDX0
	W	MWM F, Ry				

- LBF : Low Battery Detect Flag.
- ENLBD : 1 for generating pulse to enable Low Battery Detect.
- LVR2F : Reset by LVR2 Flag & can be clear by CLRLVR2=1 if set LVR2 to LVR by code option.
LBD/SWPWR state if set LVR2 to auto-LBD/SWPWR by code option(LVR2F=0/1 for 3/1.5V Power Mode).
- CLRLVR2 : Clear LVR2F if set LVR2 to LVR by code option.
- LVR2RLS : Enable LVR2F 1<->0 Halt/Interrupt Release by share with INT if set LVR2 to auto-LBD/SWPWR by code option.
- VDL3~0 : Set VDL regulator output voltage.
±50mV for one step voltage.
<VDL for VL2>
Initial value=6h for VDL=2.10V.
VDL=2.55/1.80V for VL3~0=F/0h.
<VDL for VL1>
Initial value=2h for VDL=1.05V.
VDL=1.70/0.95V for VL3~0=F/0h.
- LBD4~0 : Set Low Battery Detect Voltage.
±50mV for one step voltage.
Initial value=15/00 for LBD=2.40/1.35V at 3/1.5V Power Mode.
LBD=2.90/1.35V for LBD4~0=1F/00h.
Share to set LVR2 voltage if set LVR2 to auto-LBD by code option.
- VDX3~0 : Set VDX regulator output voltage.
Initial value=0h for VREG=1.20V.
VDX=1.95/1.20V for VDX3~0=F/0h.