



PRODUCT NAME

TP6911

TITLE

LQFP48 USB Phone Application Note

Introduction

The purpose of this application note is to provide specific design and layout guidelines. The TP6911 is an USB Audio device tailored to the USB audio speaker and voice recorder application. It is able to play two channels speaker-out and record one channel voice through Full-Speed USB bus.

Applications

- USB Audio Speaker
- USB Audio Voice Recorder
- USB Phone
- USB Earphone with Microphone

Guideline on Electrical Power

1. X'tal & PLL Circuit

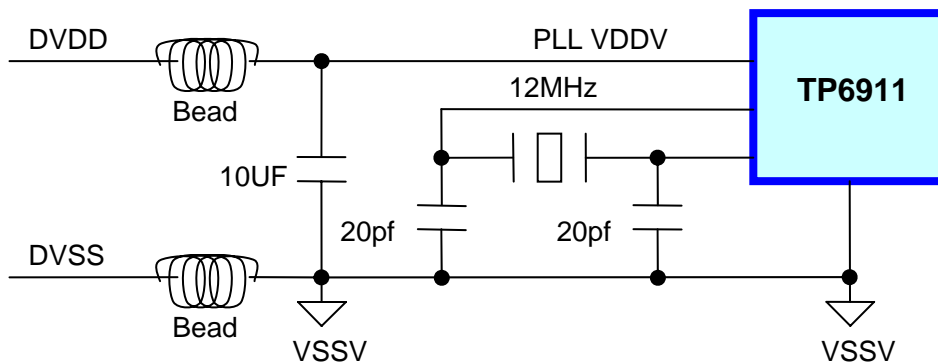

Noise on USB Power will cause phase jitter at the output of the PLL. To provide isolation from the noisy DVDD signals, VDDV / VSSV is brought to a pair of dedicated package pins.

2. USB Bus Power connect PWMVDD for Class D Speaker

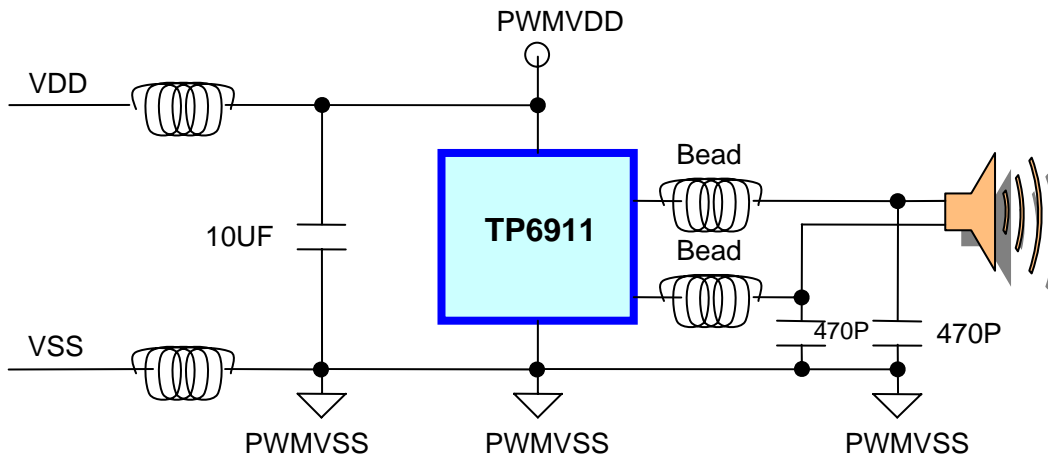

The differential SP+ and SP- pins are designed to drive a 8ohm speaker directly. A coupling capacitor is needed each the SP+/SP- pin and the speaker

3. Microphone Power Circuit

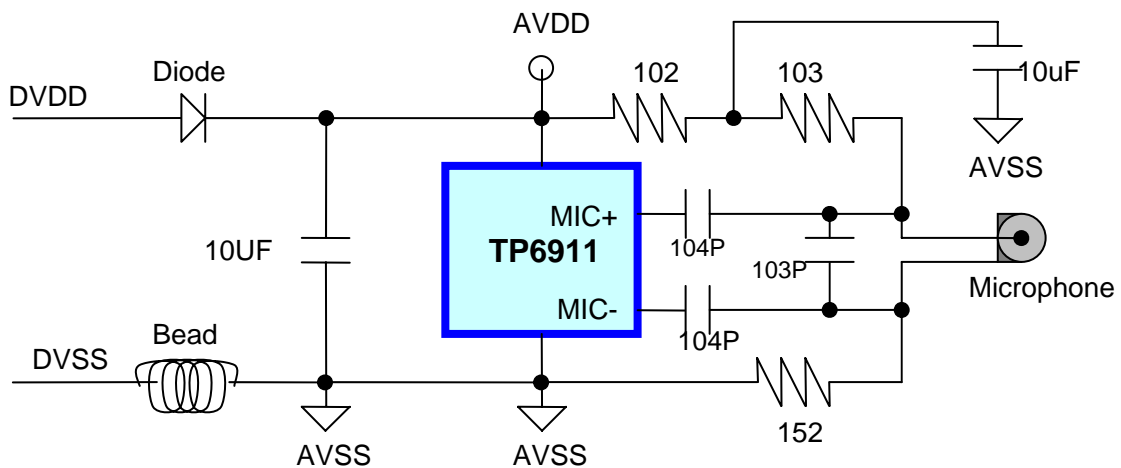

4. Analog in / out application circuit for Recording

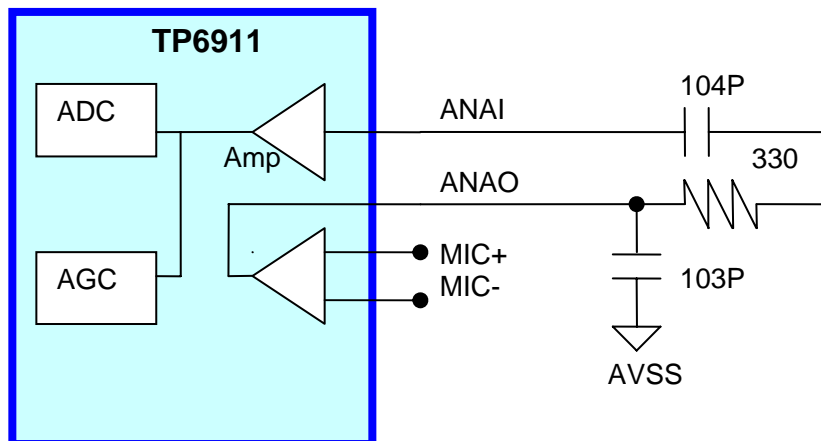

The ANA-IN transfers an input signal to the chip for recording. This ANA IN pin should be connected via an external capacitor to the ANA-OUT pin. This capacitor value, together with the 330ohm input impedance of ANA-IN, is selected to give additional cutoff at the low-frequency end of the voice pass-band. The ANA-OUT provides the preamplifier output to the user.

5. USB Full Speed Transceiver application circuit

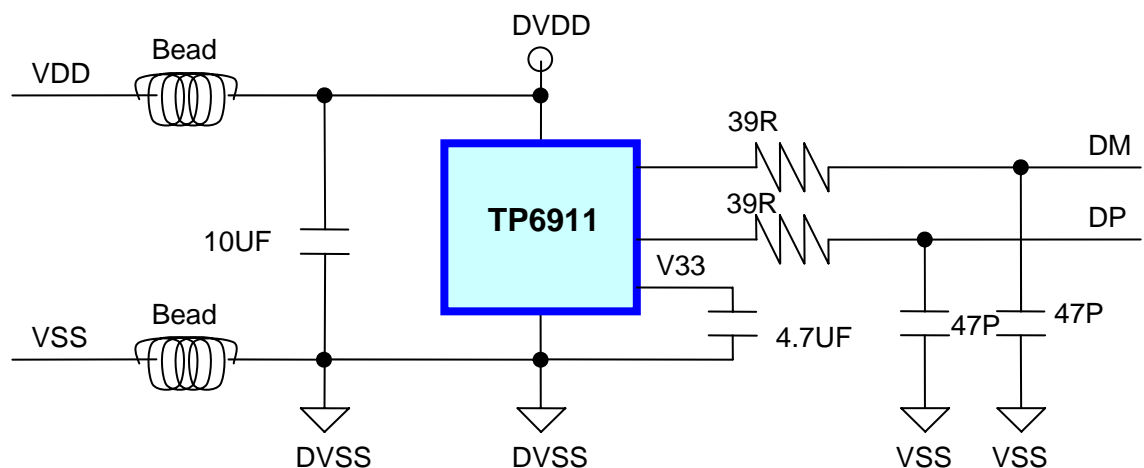

TP6911 Build-in internal regulator for USB used. The decoupling components should be connected closely to the V33 power / ground pins outside the chip

6. LED Indicators

Port 3.5 with LED Intensity control pin. It support 34mA high current to drive high-brightness LED for indicator USB status.

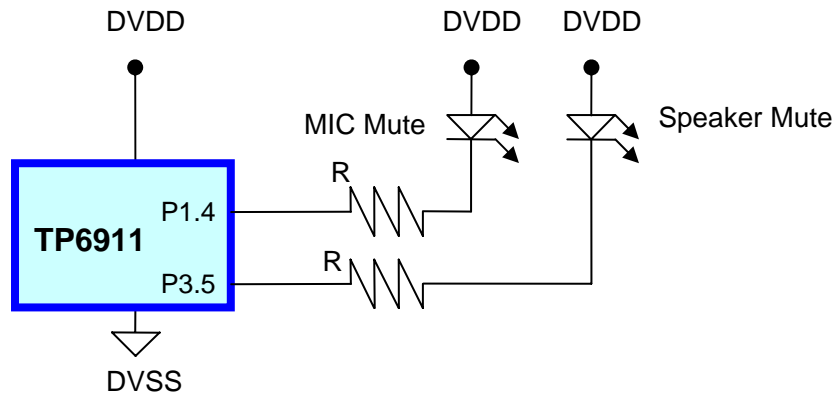

7. KSI4 Pin Define

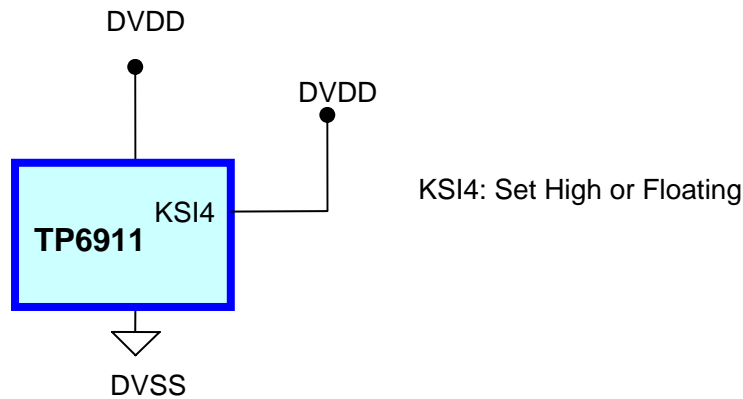

8. ADCI Pin Define

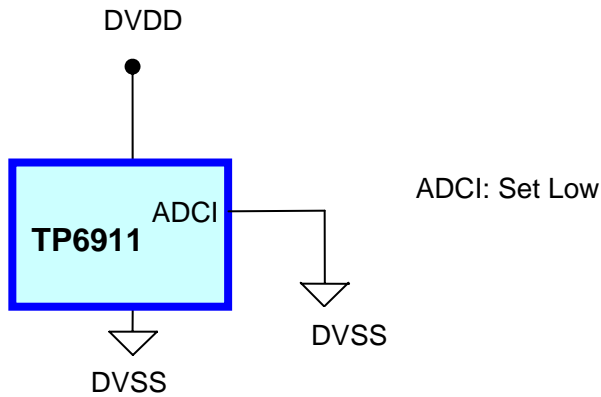

9. P1.5 Pin Define

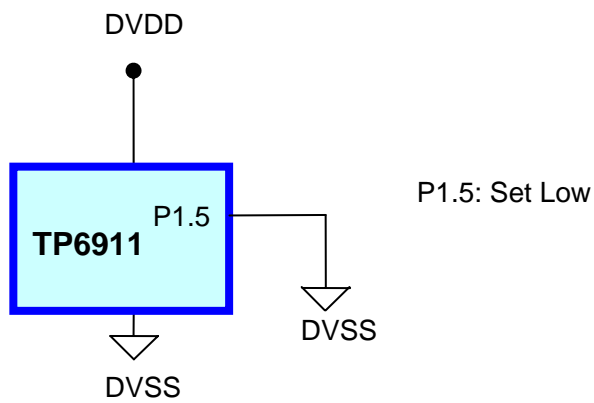

10. P1.7 Pin Define

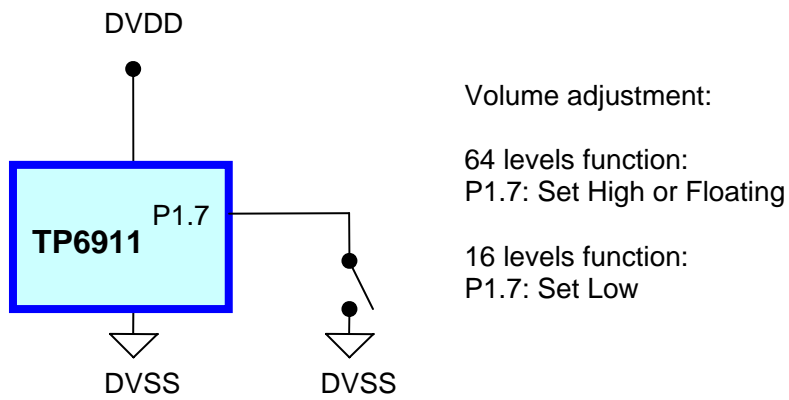

11. Key Matrix PIN Define

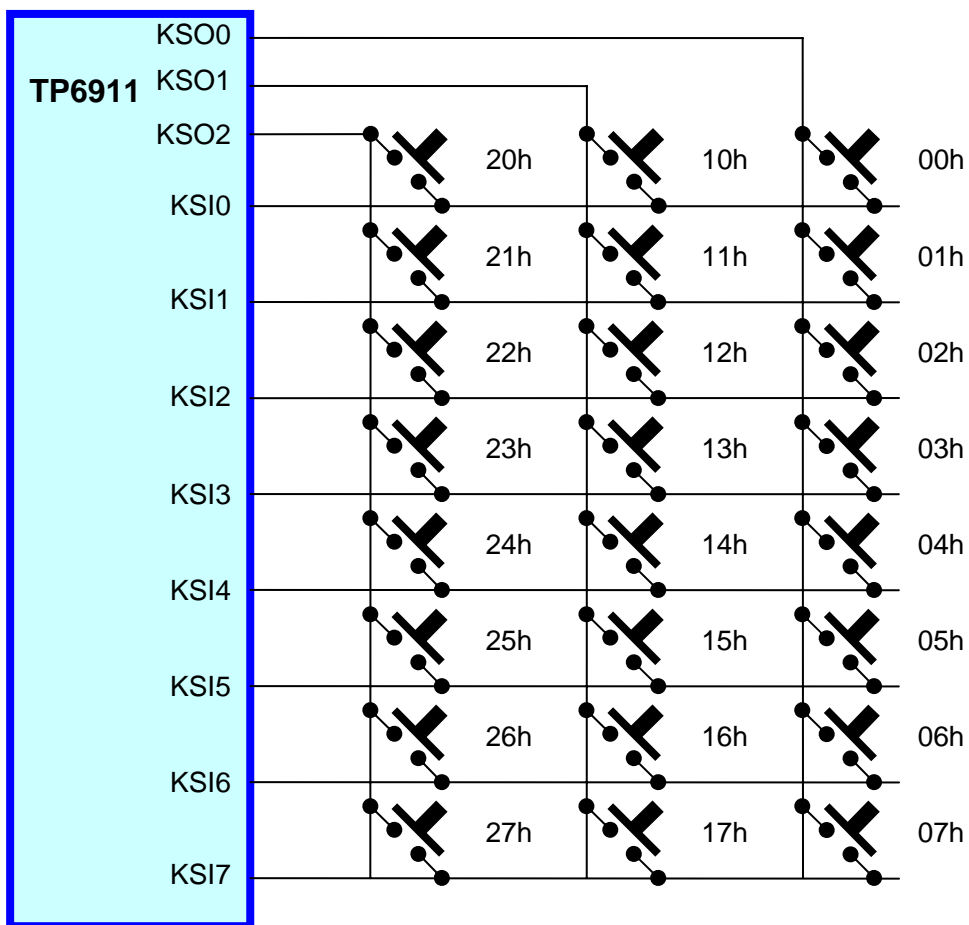

TP6911 Circuit for USB Phone

