



**PRODUCT NAME**

TP66P05 & TP66P06 for PAN301 Sensor USB Mouse Driver

**TITLE**

USB Mouse for EMI & ESD & EFT Report

**APPLICATION NOTE**

1. 線材有編織網 + 銅箔(編號 2)

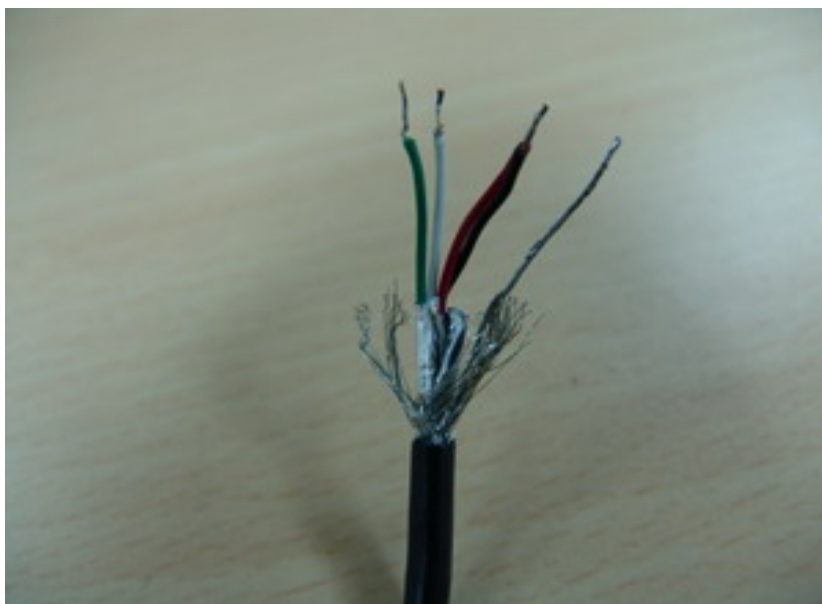

## 2. Housing



## 3. PCB 正面



4. PCB 背面

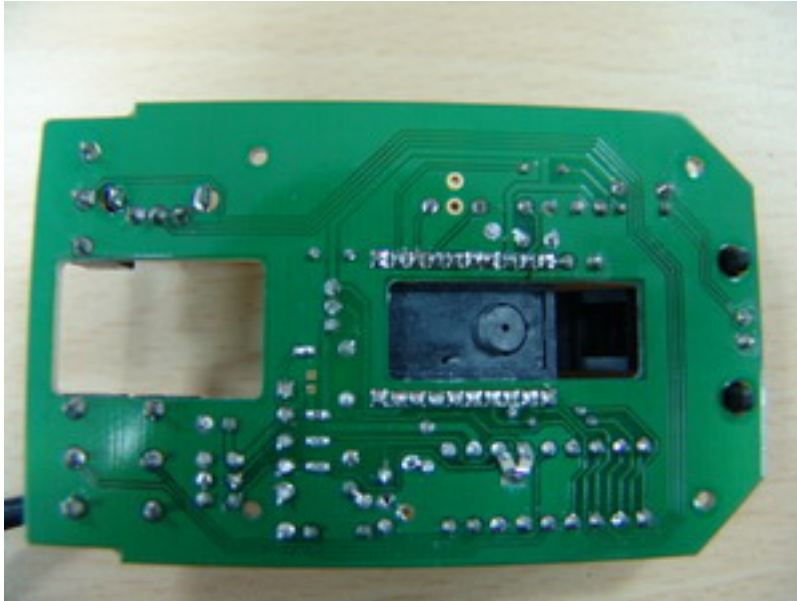

5. PCB + Housing



6. 組合



7. 電路圖

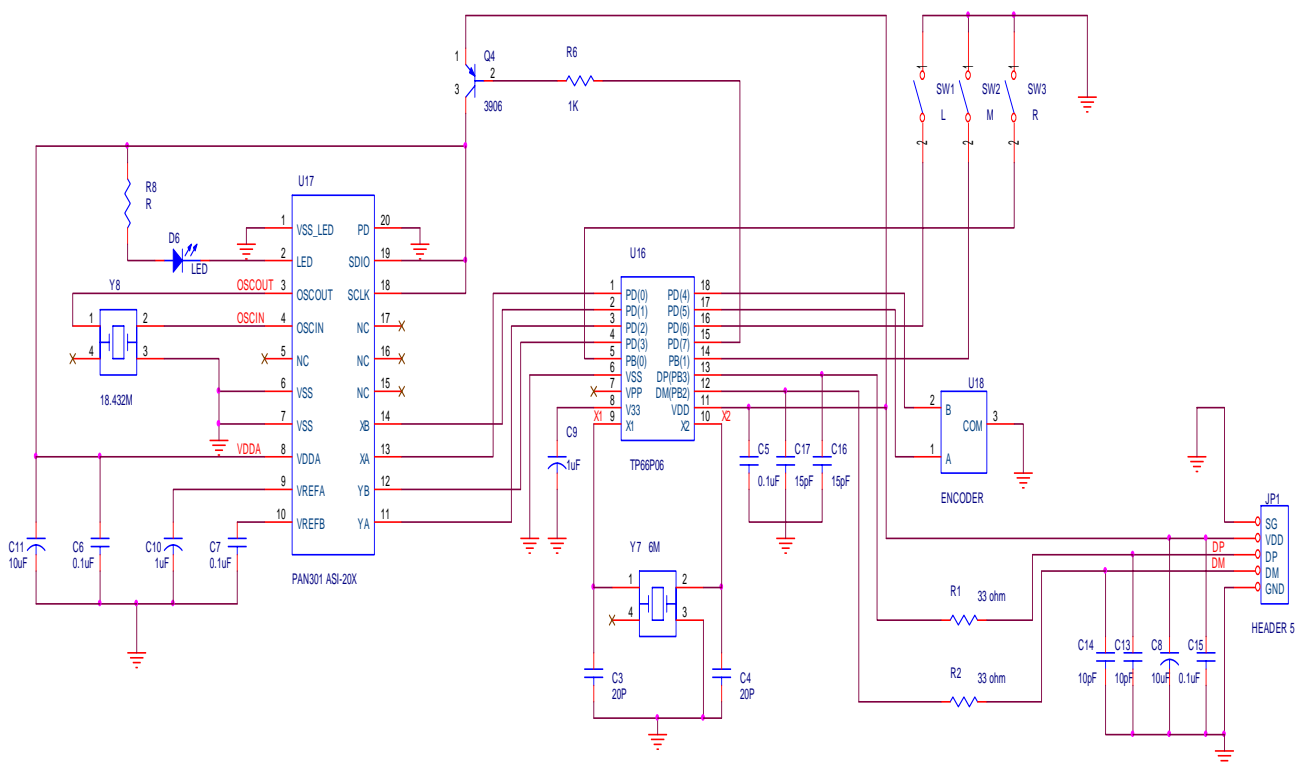

## 8. BOM 表

編號	元件數量	元件編號	元件數值	尺寸	備註
1	2	C4,C3	20pF	DIP	靠近 CRYSTAL
2	4	C5,C6,C7,C15	0.1uF	DIP	靠近 I/O 及 IC
3	2	C11,C8	10uF	DIP	靠近 I/O
4	2	C9,C10	1uF	DIP	
5	2	C14,C13	10pF	DIP	靠近 I/O
6	2	C17,C16	15pF	DIP	靠近 TP66P06 IC
7	1	D6	LED		
8	1	JP1	HEADER 5		
9	1	Q4	2N3906	DIP	
10	1	R6	1K $\Omega$	DIP 1/8W	
11	1	R8	47 $\Omega$	DIP 1/8W	
12	1	SW1	L		
13	1	SW2	M		
14	1	SW3	R		
15	1	U16	TP66P06	DIP	
16	1	U17	PAN301		
17	1	U18	ENCODER		
18	2	R1,R2	Bead 33 $\Omega$	SMD 0603	靠近 I/O
19	1	Y7	6MHZ	DIP	靠近 IC
20	1	Y8	18.432MHZ	DIP	靠近 SENSOR

9. EMI Test Report (Horizontal)

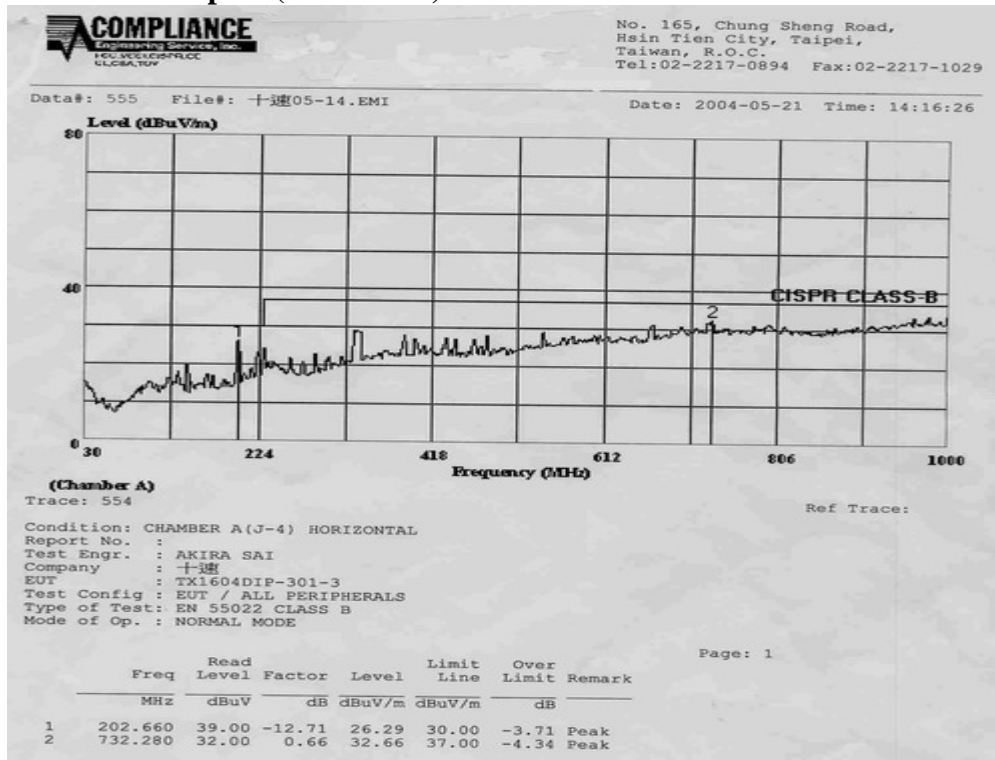

10. EMI Test Report (Vertical)

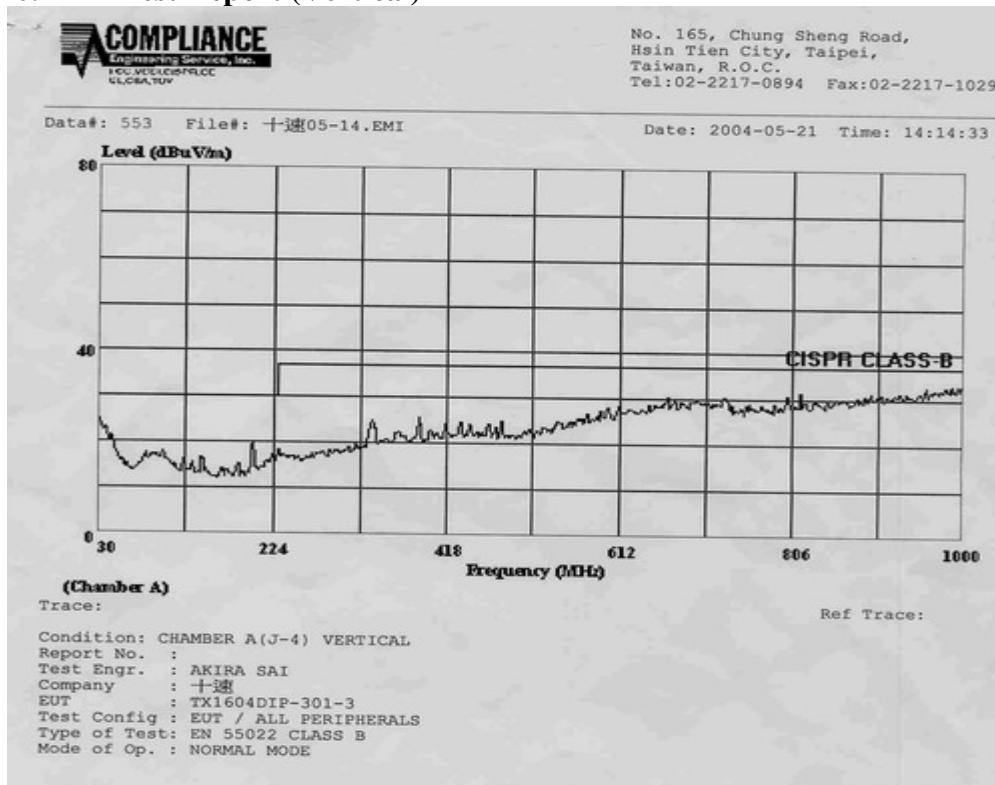

11. TP66P05 ESD Test Report



程智科技股份有限公司  
Compliance Certification Services Inc.

表格編號：FM-022A  
版本：R03  
文件編號：PA-022

**Electrostatic Discharge Test Record**



<i>Customer:</i> <u>士達</u>	<i>Test Date:</i> <u>2004/6/11</u>
<i>EUT Name:</i> <u>Mouse</u>	<i>Temp:</i> <u>20</u> °C; <i>Hum:</i> <u>60</u> %; <i>Press</i> <u>1015</u> mbar
<i>M/N:</i> <u>TP66P05</u>	<i>Tester:</i> <u>Alex Pan</u>
<i>Test Mode:</i> <u>Normal</u>	<i>Supervisor:</i> <u>Spring Wang</u>

Item	Voltage (kV)		Results		Remark
			Pass	Fail	
Air Discharge	+	8	✓		
	-	8	✓		
Contact Discharge	+	4	✓		
	-	4	✓		
Indirect Discharge HCP	+	4	✓		
	-	4	✓		
Indirect Discharge VCP (Front)	+	4	✓		
	-	4	✓		
Indirect Discharge VCP (Left)	+	4	✓		
	-	4	✓		
Indirect Discharge VCP (Back)	+	4	✓		
	-	4	✓		
Indirect Discharge VCP (Right)	+	4	✓		
	-	4	✓		

Criteria :     A     B     C

12. TP66P06 ESD Test Report



程智科技股份有限公司  
Compliance Certification Services Inc.

表格編號：FM-022A  
版 本：R03  
文件編號：BA022

**Electrostatic Discharge Test Record**



<i>Customer:</i> <u>士逵</u>	<i>Test Date :</i> <u>2004/6/11</u>
<i>EUT Name:</i> <u>Mouse</u>	<i>Temp:</i> <u>20</u> °C; <i>Hum:</i> <u>60</u> % ; <i>Press</i> <u>1015</u> mbar
<i>M/N :</i> <u>TP66P06</u>	<i>Tester:</i> <u>Alex Pan</u>
<i>Test Mode :</i> <u>Normal</u>	<i>Supervisor :</i> <u>Spring Wang</u>

Item	Voltage (kV)		Results		Remark
			Pass	Fail	
Air Discharge	+	8	✓		
	-	8	✓		
Contact Discharge	+	4	✓		
	-	4	✓		
Indirect Discharge HCP	+	4	✓		
	-	4	✓		
Indirect Discharge VCP (Front)	+	4	✓		
	-	4	✓		
Indirect Discharge VCP (Left)	+	4	✓		
	-	4	✓		
Indirect Discharge VCP (Back)	+	4	✓		
	-	4	✓		
Indirect Discharge VCP (Right)	+	4	✓		
	-	4	✓		

Criteria :     A     B     C

13. TP66P05 EFT Test Report



程智科技股份有限公司  
Compliance Certification Services Inc.

表格編號 : FM-024A  
版 本 : R03  
文件編號 : PA-024

**Electrical Fast Transient/Burst Test Record**



Customer: 十溧 Test Date : 2004/6/11  
 EUT Name: Mouse Temp: 20 °C; Hum: 60 % ; Press 1015 mbar  
 M/N : TP66P05 Test Mode : Normal  
 Voltage : Direct 1 kV  
 Clamp \_\_\_\_\_ kV Tester: Alex Pan Supervisor: Spring Wang

Inject Line	Inject Method	Results		Inject Line	Inject Method	Results	
		Pass	Fail			Pass	Fail
L1	Direct	✓			Clamp		
N	Direct	✓			Clamp		
PE	Direct	✓			Clamp		
L1+N	Direct	✓			Clamp		
L1+PE	Direct	✓			Clamp		
N+PE	Direct	✓			Clamp		
L1+N+PE	Direct	✓			Clamp		
	Direct				Clamp		
	Direct				Clamp		
	Direct				Clamp		
	Direct				Clamp		

Remark :

Criteria :  A  B  C

14. TP66P06 ESD Test Report



程智科技股份有限公司  
Compliance Certification Services Inc.

表格編號 : FM-024A  
版 本 : R03  
文件編號 : PA-024

**Electrical Fast Transient/Burst Test Record**



Customer: <u>十遠</u>	Test Date : <u>2004/6/11</u>
EUT Name: <u>Mouse</u>	Temp: <u>20</u> °C; Hum: <u>60</u> % ; Press <u>1015</u> mbar
M/N : <u>TP66P06</u>	Test Mode : <u>Normal</u>
Voltage : Direct <u>1</u> kV Clamp _____ kV	Tester: <u>Alex Pan</u> Supervisor: <u>Spring Wang</u>

Inject Line	Inject Method	Results		Inject Line	Inject Method	Results	
		Pass	Fail			Pass	Fail
L1	Direct	✓			Clamp		
N	Direct	✓			Clamp		
PE	Direct	✓			Clamp		
L1+N	Direct	✓			Clamp		
L1+PE	Direct	✓			Clamp		
N+PE	Direct	✓			Clamp		
L1+N+PE	Direct	✓			Clamp		
	Direct				Clamp		
	Direct				Clamp		
	Direct				Clamp		
	Direct				Clamp		

Remark :

Criteria :  A  B  C

P.S "此測試結果僅針對與測試報告中相同的 PCB Layout, USB 線材與 Housing等條件, 對於不同的設計條件須視實際需要做調整,以符合 EMC 的規範."